

Accuflow™ Series Low Flow Rate Waterflow Detectors



Models Available

LFD20
LFD25-73MM
LFD25-76MM
LFD30-2
LFD40

Replacement Parts

WFDW	Cover wrench
546-9000	Cover tamper switch kit
WFDN4	Gasket kit

LFD30-2



LFD30-2 (cover removed)



Product Overview

For use in wet pipe water mist systems

Compatible with 2 to 4 inch stainless steel and brass pipe

Solid state retard assures precise timing accuracy

Dipswitch selections simplify retard settings

Non-polarized, two-wire design allows connection to a local bell and conventional or addressable systems

NEMA 4 rated

Synchronized switches activate both the alarm panel and local bell simultaneously

System Sensor's Accuflow™ Low Flow Rate detectors are a new line of solid state waterflow detectors designed for use in wet pipe water mist systems where low flow detection is required.

Robust Construction. Accuflow low flow detectors consist of a rugged enclosure for indoor and outdoor use. Like all System Sensor waterflow detectors, low flow models operate across a wide temperature range, from 32°F to 120°F (0°C to 49°C).

Reliable Performance. Accuflow low flow detectors are intended for applications where flow detection of 3 GPM or greater is required. By incorporating a solid state retard, proper sensitivity, timing accuracy and switch resetting is assured.

False Alarm Immunity. The solid state circuitry of Accuflow low flow detectors provides greater timing accuracy over traditional mechanical retard designs. This accuracy minimizes the risk of false alarms created by pressure surges or air trapped within the sprinkler system.

Simplified Operation. Accuflow low flow detectors are designed to simplify installation. Wired like traditional waterflow detectors, these models do not require the installer to run an additional third wire. Two conduit openings permit easy attachment to the local alarm system.



Engineering Specification

Low flow rate vane-type waterflow detector with solid state retard shall be an Accuflow model number _____ manufactured by System Sensor, and shall be installed on system piping as designated on the drawing and/or as specified herein. Detectors shall mount on a stainless steel clear pipe span of the appropriate nominal size, either on a vertical upflow of horizontal run, at least 6" from any fittings which may change water direction, flow rate, or pipe diameter, or no closer than 24" from a valve or drain. Detectors shall be compatible with 2" through 4" diameter stainless steel and brass pipe. Detectors shall have a sensitivity of 3 gallons (11.35 liters) per minute minimum and a static pressure of 450 psi for 2" – 4" diameter pipes. The detector shall respond to water flow in the specified direction after a preset time delay. The delay mechanism shall be a solid state unit which is field-adjustable via a dipswitch. The detector's actuation mechanism shall include a polyethylene vane inserted through a hole in the pipe and connected by a mechanical linkage to the delay mechanism. Outputs shall consist of one SPDT switch (Form C contact) and one SPST switch (normally open contact) for wiring to an alarm panel or addressable control module and local bell and/or notification device. Two conduit entrances (one knockout type) for standard fittings of commonly used electrical conduit shall be provided on the detectors. A grounding provision shall be provided. Unless noted, enclosures shall be NEMA 4 listed by Underwriters Laboratories, Inc. for indoor or outdoor use.

Standard Specifications

Static Pressure Rating

450 PSI

Triggering Threshold Bandwidth (Flow Rate)

3 GPM (11.35 liters/minute)

Maximum Surge

18 Feet Per Second (FPS)

Compatible Pipe

Stainless steel and brass water pipe, 2" through 4" (refer to Ordering Information below)

Overall Dimensions Installed

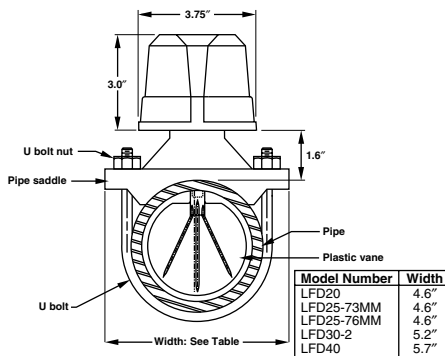

Contact Ratings

One SPDT (Form C)
One SPST (normally open)
0.6 A @ 125 VAC
2.0 A @ 30 VDC

Voltage Range

8.4-35V (DC-FWR)
108-132 VAC

Current Draw

300 microamps @ 12/24 V(DC-FWR)
400 microamps @ 120 VAC

Conduit Entrances

Two openings for 1/2" conduit, one open, one knock-out type

Operating Temperature Range

32°F - 120°F (0°C to 49°C)

Enclosure Rating

NEMA 4 - suitable for indoor/outdoor use

Cover Tamper Switch

Optional, part no. 546-9000

Shipping Weight

LFD20: 4.1 lbs. (1.8 kg)
LFD25-73MM: 4.2 lbs. (1.9 kg)
AFD25-76MM: 4.2 lbs. (2.0 kg)
LFD30-2: 4.4 lbs. (2.1 kg)
LFD40: 5.1 lbs. (2.3 kg)

Service Use

Water mist systems where low flow detection is required.

Warranty

3 years

U.S. Patent No.

6,084,521

Ordering Information

Model Numbers	Nominal Pipe O.D. and Wall Thickness	Hole Size
LFD20	2" (60.3 mm OD), 3.9 mm to 4.5 mm	1-1/4"
LFD25-73MM	2-1/2" (73.0 mm OD), 4.8 mm to 5.2 mm	1-1/4"
LFD25-76MM	2-1/2" (76.1 mm OD), 4.3 mm to 4.7 mm	1-1/4"
LFD30-2	3" (88.9 mm OD), 5.0 mm to 5.6 mm	2"
LFD40	4" (114.3 mm OD), 5.4 mm to 6.4 mm	2"

Replacement Part Number	Description
546-9000	Cover tamper switch kit
WFDW	Tamper proof wrench for cover
WFDN4	Gasket kit

System Sensor Sales and Service

System Sensor Headquarters

3825 Ohio Avenue
St. Charles, IL 60174
Ph: 800-SENSOR2
Fx: 630/377-6495
Documents On Demand:
1-800-736-7672 x3
Web: www.systemsensor.com

System Sensor in Canada

Ph: 905.812.0767
Fx: 905.812.0771

System Sensor in Europe

Ph: + 44.1403.276500
Fx: + 44.1403.276501

System Sensor in China

Ph: + 86.29.524.6253
Fx: + 86.29.524.6259

System Sensor in Singapore

Ph: + 65.273.2230
Fx: + 65.273.2610

System Sensor in the Far East

Ph: + 852.21919003
Fx: + 852.27366580

System Sensor in Australia

Ph: + 613.54.281.142
Fx: + 613.54.281.172

System Sensor in India

Ph: + 91.11.558.2119
Fx: + 91.11.567.6815