



MOM5C - Multi Output Power Distribution Module for Access Control

Overview:

The MOM5(C) multi output power distribution module converts one (1) non-power limited DC voltage input to five (5) power limited outputs. Each output will route power to a variety of access control hardware and devices which includes Mag Locks, Electric Strikes, Magnetic Door Holders, etc... These outputs will operate in both fail-safe and fail-secure modes. Controlled trigger input is achieved through normally open (N.O.) or normally closed (N.C.) supervised input or the polarity reversal from an FACP (Fire Alarm Control Panel). A form "C" dry output relay will enable HVAC Shutdown, Elevator Recall or trigger auxiliary devices.

Specifications:

Agency Listings:

- UL Listed for Access Control System Units (UL294), Standard for Safety for Fire Protective Signaling Systems(UL1481)
- NYC Department of Buildings Approved (MEA)
- California State Fire Marshal Approved (CSFM)
- NFPA72 compliant.



Input:

- 12VDC or 24VDC from power supply.

Output:

- 12VDC or 24VDC selectable outputs.
- Five (5) individual power limited class 2 outputs.
- Current limit is 2.5 amp @ 12VDC or 24VDC per output.
- Output relay indicates that unit is triggered. (Form "C" contact rated 1 amp @ 28VDC/115VAC).

Visual Indicators:

- Red LED's indicate condition of each power output.
- Power & input trigger LED's.

Supervision:

- Fire Alarm Panel or Access Control System trigger inputs. (N.O. or N.C. supervised trigger input and polarity reversal trigger input).
- Power fail supervision relay (Form "C" contact rated 1 amp @ 28VDC/115VAC).

Special Features:

- Interfaces with most DC Power Supplies.
- Will interface with most UL Listed Power Supplies

Enclosure Dimensions:

8"H x 7.25"W x 3.5"D

Installation Instructions:

1. Mount the MOM5C in desired location.
2. Connect the DC of the power supply to the terminals marked [- DC input +] carefully observing polarity.
3. Connect door strikes (fail-secure) positive to terminals marked 1 thru 5 Pos. (+) DC Output (alarm) and negative to [NEG. 1] thru [NEG. 5].
4. Connect door holders (fail-safe) positive to terminals marked [6 thru 10 Pos. (+) DC Output (stand-by)] and negative to [NEG. 1] thru [NEG. 5].
5. To trigger the MOM5C from a FACP connect signaling circuit of FACP to inputs marked [NEG. (-)] and [POS. (+)] input. Polarity is shown in alarm condition. Put wires coming to each terminal on different sides of the screw.
6. To trigger the MOM5C using a supervised dry contact connect the 2.2K resistor in series for a N.C. trigger input and in parallel for N.O. trigger input.
7. Connect the auxiliary devices that are to be triggered by the MOM5C to the terminals marked [N.O. & C] for normally open outputs and terminals marked [N.C. & C] for normally closed output.
Note: This relay will energize when the MOM5C is triggered.
8. Connect trouble reporting device to the terminals marked [POWER FAIL]. Connect to the N.O. & C for normally open and N.C. & C for normally closed output.
Note: This relay will switch when power is lost to the MOM5C.

LED Diagnostic Table:

LED	ON	OFF
Power (Green)	Normal operation.	Loss of power to MOM5(C).
Trigger (Green)	MOM5(C) triggered (alarm condition).	MOM5(C) in standby (non-alarm condition).
Outputs (Red)	Output tripped due to a short circuit or overload condition.	Normal operation.

Terminal Identification:

Terminal Legend	Function/Description
- DC Input +	12VDC or 24VDC from power supply.
Trigger	This circuit is supervised by a 2.2 K EOL resistor. Initiating a short or open will cause power to be dropped to all terminals marked Pos. (+) DC output (standby) and supply power to all terminals marked Pos (+) DC output (alarm).
Input Neg (-), Pos (+)	Applying voltage to terminals marked Neg(-) input Pos (+) FACP signaling output in polarity shown will yield the same results as initiating trigger (mentioned above).
Neg (-) 1 thru 5	Supplies constant negative (-) voltage.
Pos (+) DC output (alarm)	Supplies positive (+) voltage when dry input or fire alarm (wet) trigger input.
Pos (+) DC output (standby)	Supplies positive (+) voltage in normal condition. Power is removed when either input trigger is activated.
N.C., C, N.O. Dry output	When the MOM5(C) is triggered the C and N.O. terminals will open and the C and N.C. terminals will close. This output is used to trip auxiliary devices. e.g. HVAC Shutdown, Elevator Recall etc...
N.C., C, N.O. Power Fail	Form "C" contacts used for signaling when no voltage is present at - DC input + terminals. Under normal conditions, terminals N.O. and C are open, N.C. and C are closed. A occurrence of trouble condition causes N.O. and C to closed and N.C. and C to open.

Typical Application Diagrams:

Fig. 1 MOM5C module shown with wet and/or dry normally closed trigger inputs (**Non-Latching**):

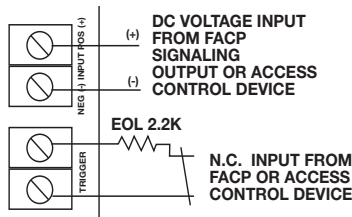

MOM5C module shown with wet and/or dry normally open trigger inputs (**Non-Latching**):

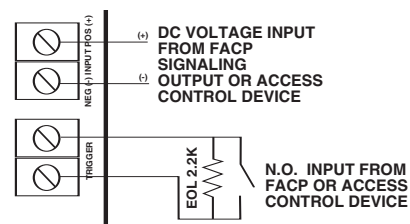
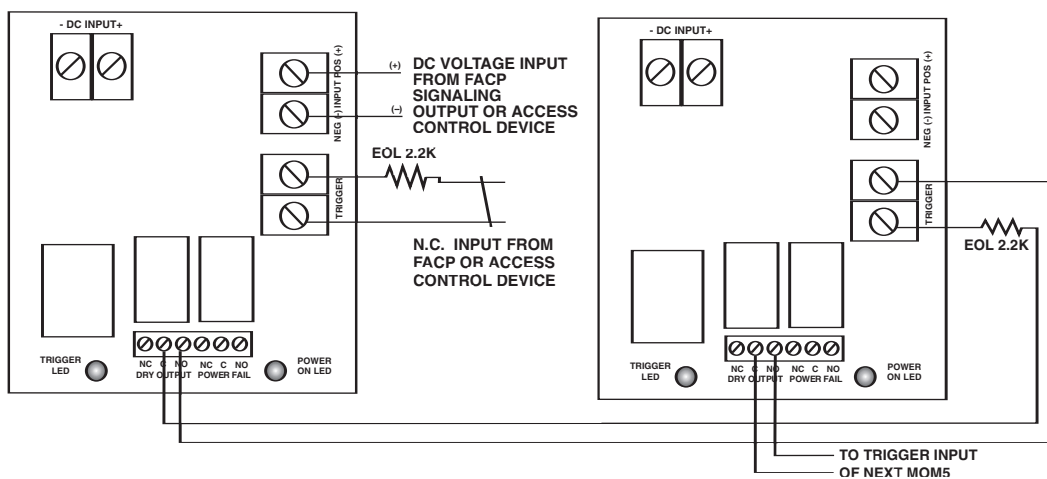

Fig. 2 - Two (2) or more MOM5C modules shown with wet and/or dry normally closed trigger inputs (**Non-Latching**):



Typical Application Diagrams:

Fig. 3 - Two (2) or more MOM5C modules shown with wet and/or dry normally open trigger inputs (**Non-Latching**):

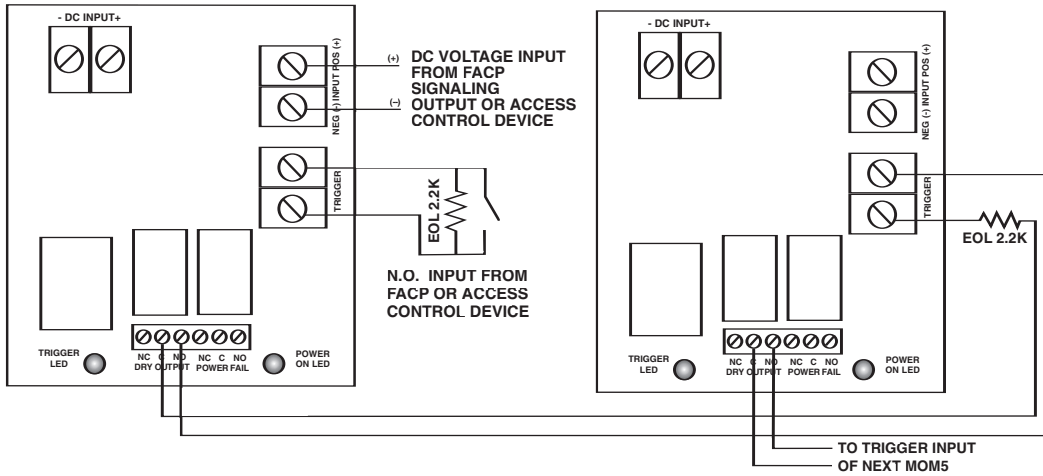
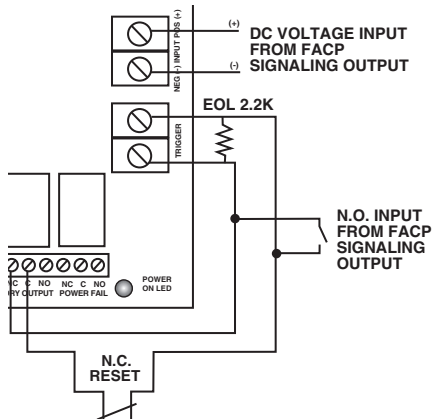

Fig. 4 MOM5C module shown with with wet and/or dry normally closed fire alarm trigger inputs (**Latching with Manual Reset**):



MOM5C module shown with with wet and/or dry normally open fire alarm trigger inputs (**Latching with Manual Reset**):

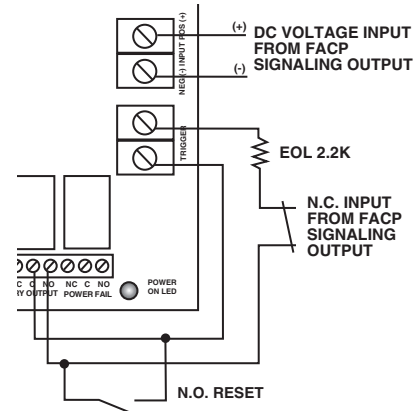

Fig. 5 - Two (2) MOM5C modules shown with wet and/or dry normally closed fire alarm trigger inputs (**Latching with Manual Reset**):

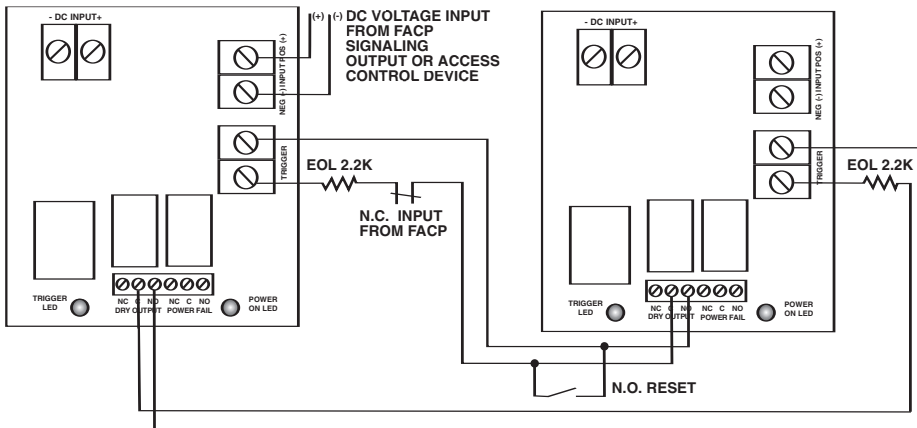

Fig. 6 - Two (2) MOM5C modules shown with wet and/or dry normally open fire alarm trigger inputs (**Latching with Manual Reset**):

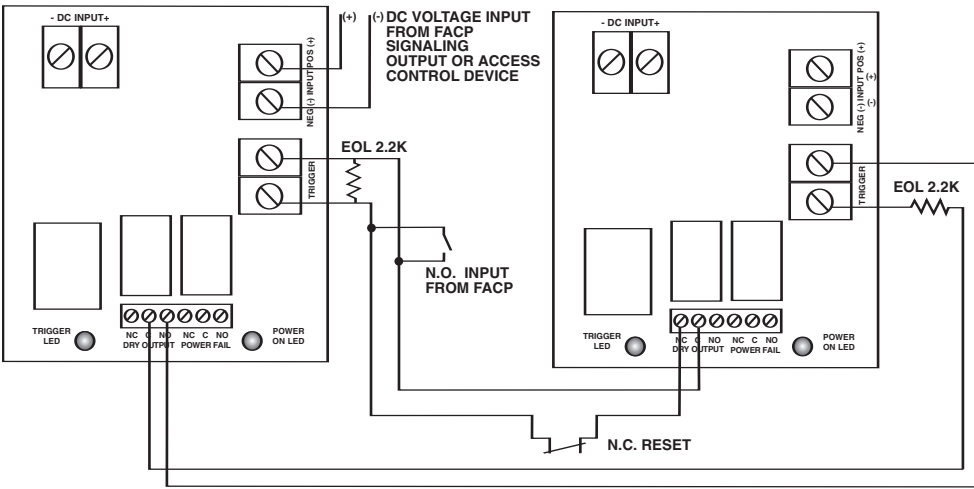
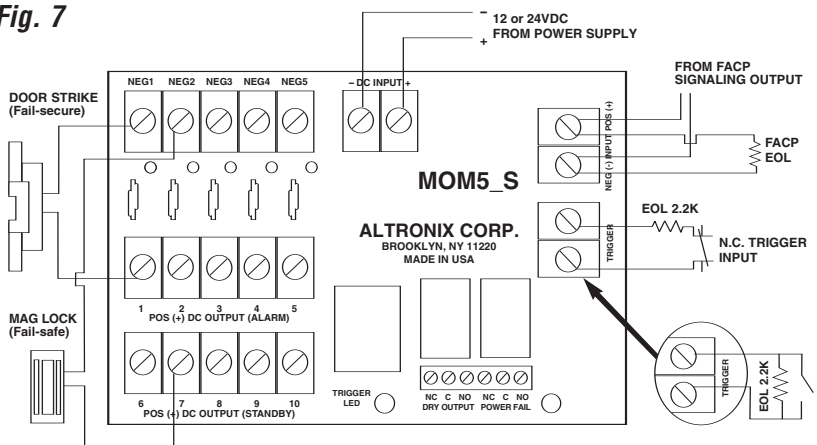
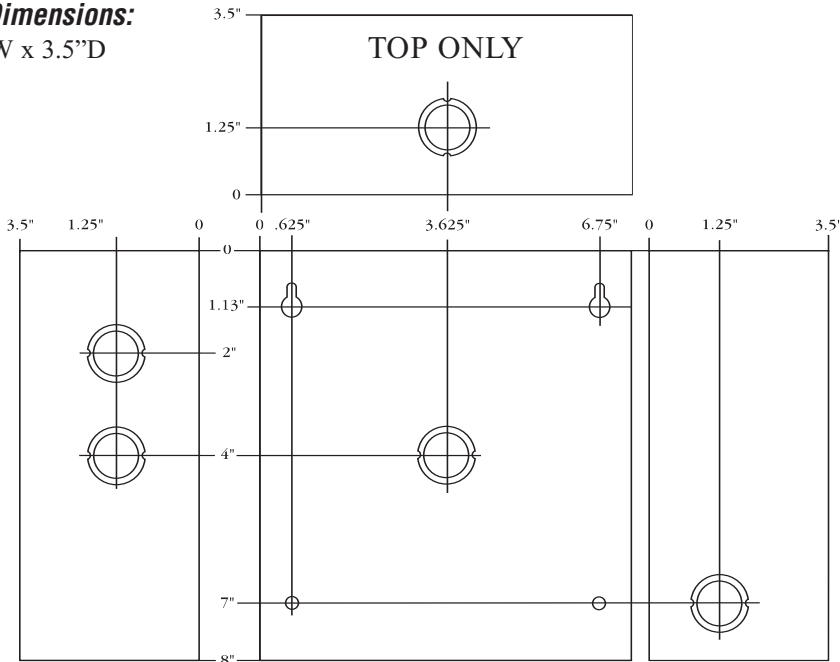

Fig. 7



Enclosure Dimensions:

8”H x 7.25”W x 3.5”D



Altronix is not responsible for any typographical errors.

140 58th Street, Brooklyn, New York 11220 USA, 718-567-8181, fax: 718-567-9056
 website: www.altronix.com, e-mail: info@altronix.com, Lifetime Warranty, Made in U.S.A.
 IIMOM5C - 120601 K08F

