



# MOM5 - Multi Output Power Distribution Module for Access Control

Rev. 012100

## Overview:

The MOM5 multi output power distribution module converts one (1) non-power limited DC voltage input to five (5) power limited outputs. Each output will route power to a variety of access control hardware and devices which includes Mag Locks, Electric Strikes, Magnetic Door Holders, etc... These outputs will operate in both fail-safe and fail-secure modes. Controlled trigger input is achieved through normally open (N.O.) or normally closed (N.C.) supervised input or the polarity reversal from an FACP (Fire Alarm Control Panel). A form “C” dry output relay will enable HVAC Shutdown, Elevator Recall or trigger auxiliary devices.

## Specifications:

- NFPA72 compliant.
  - Class 2 Rated outputs.
  - 12VDC or 24VDC operation.
  - Five (5) individual PTC protected power limited outputs.
  - Current limit is 2 amp @ 12VDC or 24VDC per output.
  - Fire Alarm Panel or Access Control System trigger inputs (NO or NC supervised trigger input and polarity reversal trigger input).
  - Red LED’s indicate condition of each power output.
  - Power & input trigger LED’s.
  - Power fail supervision relay (Form “C” contact rated 1 amp @ 28VDC).
  - Output relay indicates that unit is triggered (Form “C” contact rated 1 amp @ 28VDC).
  - Interfaces with most DC Power Supplies.
  - UL Recognized for use with AL300ULX, AL400ULX, AL600ULX, AL1012ULX & AL1024ULX Power Supplies.
- Board Dimensions (approximate):  
5.25”L x 3.5”W x 1”H

## Current Draw:

Input Voltage	Stand-by	Alarm
12VDC	0.024 amp	0.066 amp
24VDC	0.026 amp	0.074 amp

## Installation Instructions:

1. Connect the DC of the power supply to the terminals marked [-DC Input +] carefully observing polarity.
2. Connect door strikes (fail-secure) positive to terminals marked [1 thru 5 Pos. (+) DC Output (Alarm)] and negative to [NEG1] thru [NEG5] (fig. 7, pg. 4).
3. Connect mag locks, door holders (fail-safe) positive to terminals marked [6 thru 10 Pos. (+) DC Output (Stand-by)] and negative to [NEG1] thru [NEG5] (fig. 7, pg. 4).
4. To trigger the MOM5C from a FACP connect signaling circuit of FACP to terminals marked [- INPUT +]. Polarity is shown in alarm condition. Connect the wires on opposite sides of the screw.
5. To trigger the MOM5C using a supervised dry contact connect a 2.2K resistor in series to terminals marked [TRIGGER] for a NC (Normally Closed) trigger input or connect a 2.2K resistor in parallel to terminals marked [TRIGGER] for NO (Normally Open) trigger input (fig. 7, pg. 4).
6. Connect the auxiliary devices that are to be triggered by the MOM5 to terminals marked [Dry Output]:  
For Normally Open operation connect wires to the terminals marked [NO & C].  
For Normally Closed operation connect wires to the terminals marked [NC & C].  
**Note:** This relay will energize when the MOM5C is triggered.
7. Connect trouble reporting device to the terminals marked [Power Fail].  
For Normally Open operation connect wires to the terminals marked [NO & C].  
For Normally Closed operation connect wires to the terminals marked [NC & C].  
**Note:** This relay will switch when power is lost to the MOM5C.

### **LED Diagnostic Table:**

LED	ON	OFF
Power (Green)	Normal operation.	Loss of power to MOM5.
Trigger (Green)	MOM5 triggered (alarm condition).	MOM5 in standby (non-alarm condition).
Outputs (Red)	Output tripped due to a short circuit or overload condition.	Normal operation.

### **Terminal Identification:**

Terminal Legend	Function/Description
- DC INPUT +	12VDC or 24VDC from power supply.
TRIGGER	This circuit is supervised by a 2.2 K EOL resistor. Initiating a short or open will cause power to be dropped to all terminals marked [Pos. (+) DC Output (Stand-by)] and supply power to all terminals marked [Pos (+) DC Output (Alarm)].
- INPUT +	Applying voltage to terminals marked [- Input +] FACP signaling output in polarity shown will yield the same results as initiating trigger (mentioned above).
NEG1 thru NEG5	Supplies constant negative (-) voltage.
POS (+) DC OUTPUT (ALARM)	Supplies positive (+) voltage when dry input or fire alarm (wet) trigger input.
POS (+) DC OUTPUT (STANDBY)	Supplies positive (+) voltage in normal condition. Power is removed when either input trigger is activated.
NC, C, NO DRY OUTPUT	When the MOM5 is triggered the C and N.O. terminals will close and the C and N.C. terminals will open. This output is used to trip auxiliary devices. e.g. HVAC Shutdown, Elevator Recall etc...
NC, C, NO POWER FAIL	Form "C" contacts used for signaling when no voltage is present at [- DC input +] terminals. Under normal conditions, terminals marked [NO and C] are open, and terminals marked [NC and C] are closed. A occurrence of trouble condition causes terminals marked [NO and C] to closed and [NC and C] to open.

### **Typical Application Diagrams:**

Fig. 1 - MOM5 module shown with wet and/or dry normally closed trigger inputs (**Non-Latching**):

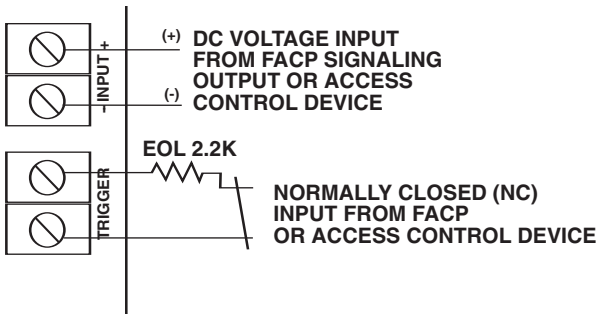

MOM5 module shown with wet and/or dry normally open trigger inputs (**Non-Latching**):

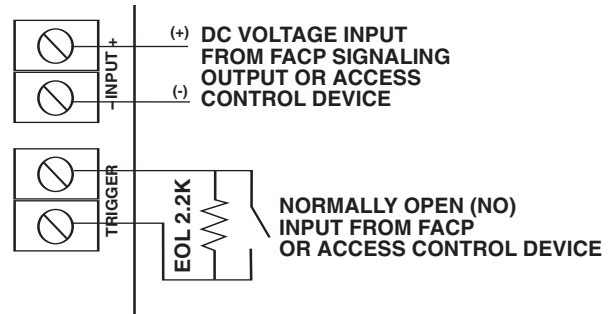

### Typical Application Diagrams:

Fig. 2 - Two (2) or more MOM5 modules shown with wet and/or dry normally closed trigger inputs (**Non-Latching**):

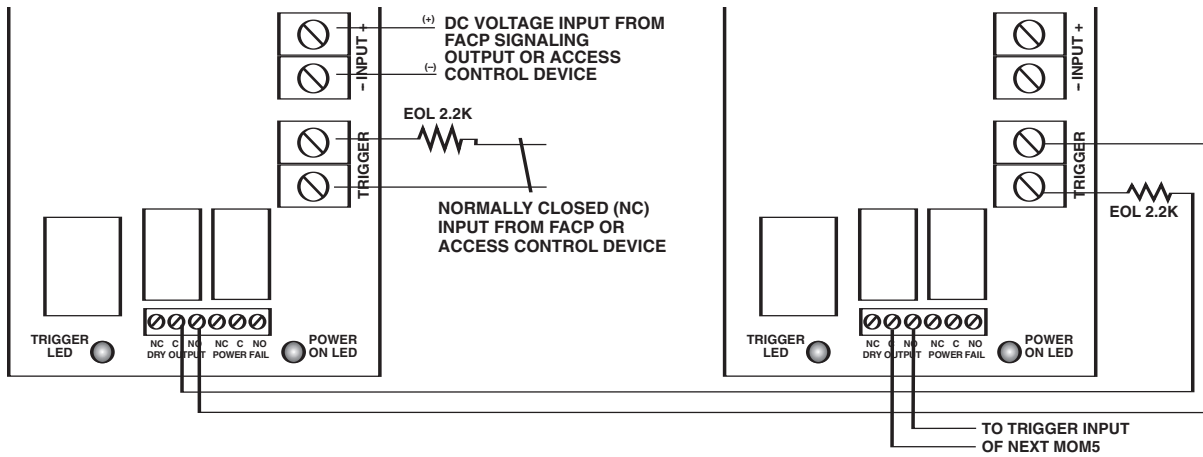

Fig. 3 - Two (2) or more MOM5 modules shown with wet and/or dry normally open trigger inputs (**Non-Latching**):

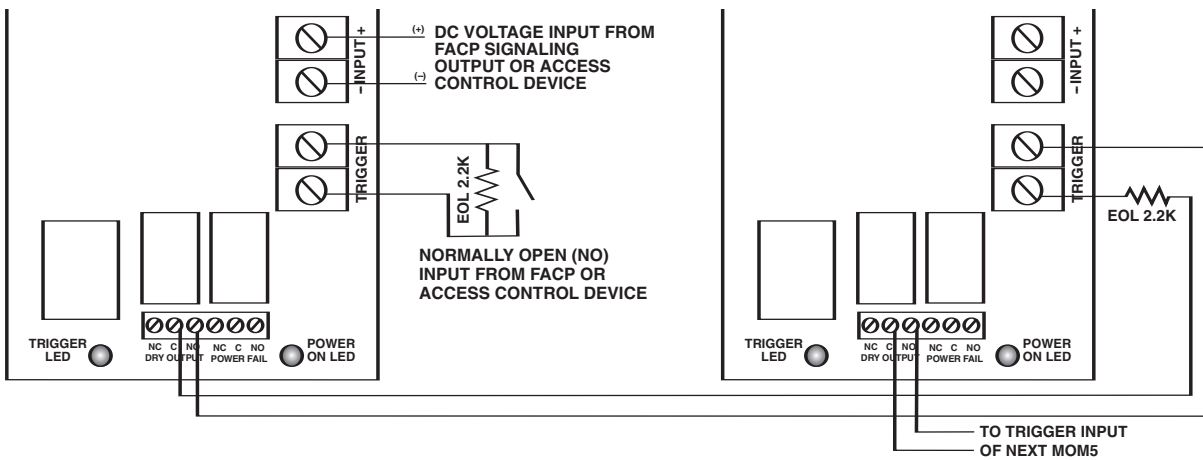
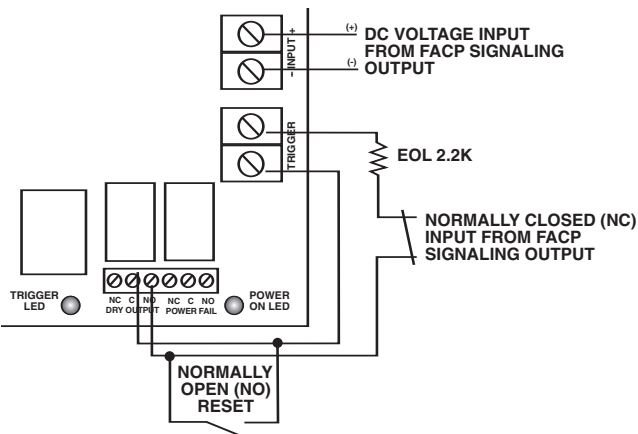

Fig. 4 - MOM5 module shown with with wet and/or dry normally closed fire alarm trigger inputs (**Latching with Manual Reset**):



MOM5 module shown with with wet and/or dry normally open fire alarm trigger inputs (**Latching with Manual Reset**):

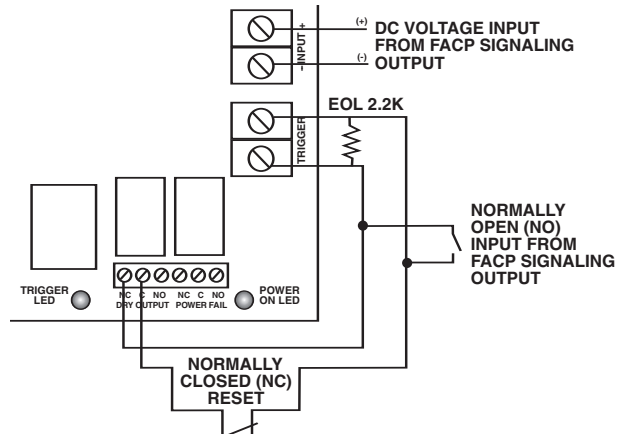

Fig. 5 - Two (2) MOM5 modules shown with wet and/or dry normally closed fire alarm trigger inputs (Latching with Manual Reset):

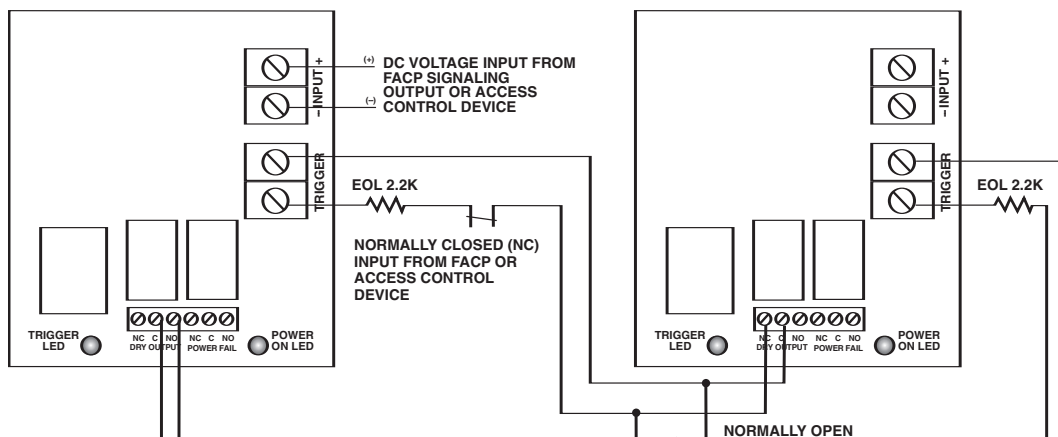

Fig. 6 - Two (2) MOM5 modules shown with wet and/or dry normally open fire alarm trigger inputs (Latching with Manual Reset):

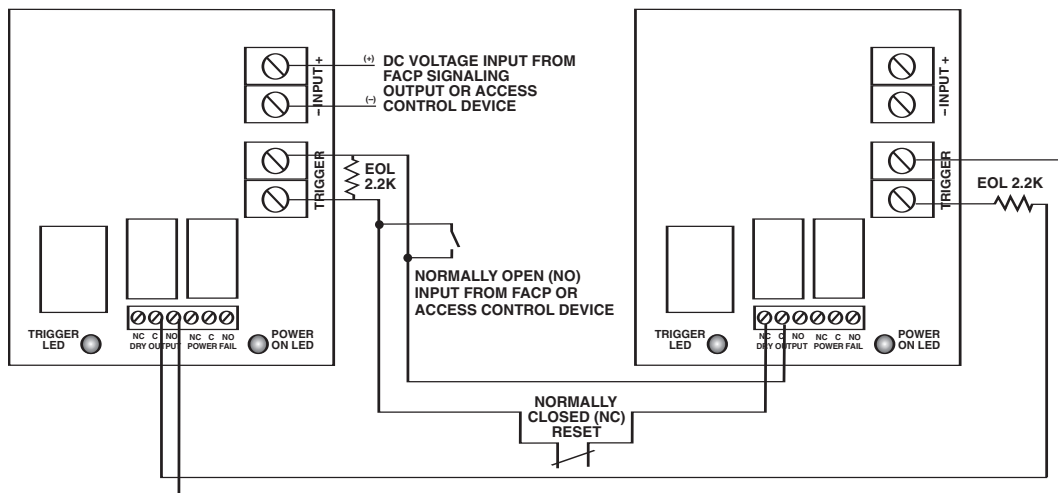
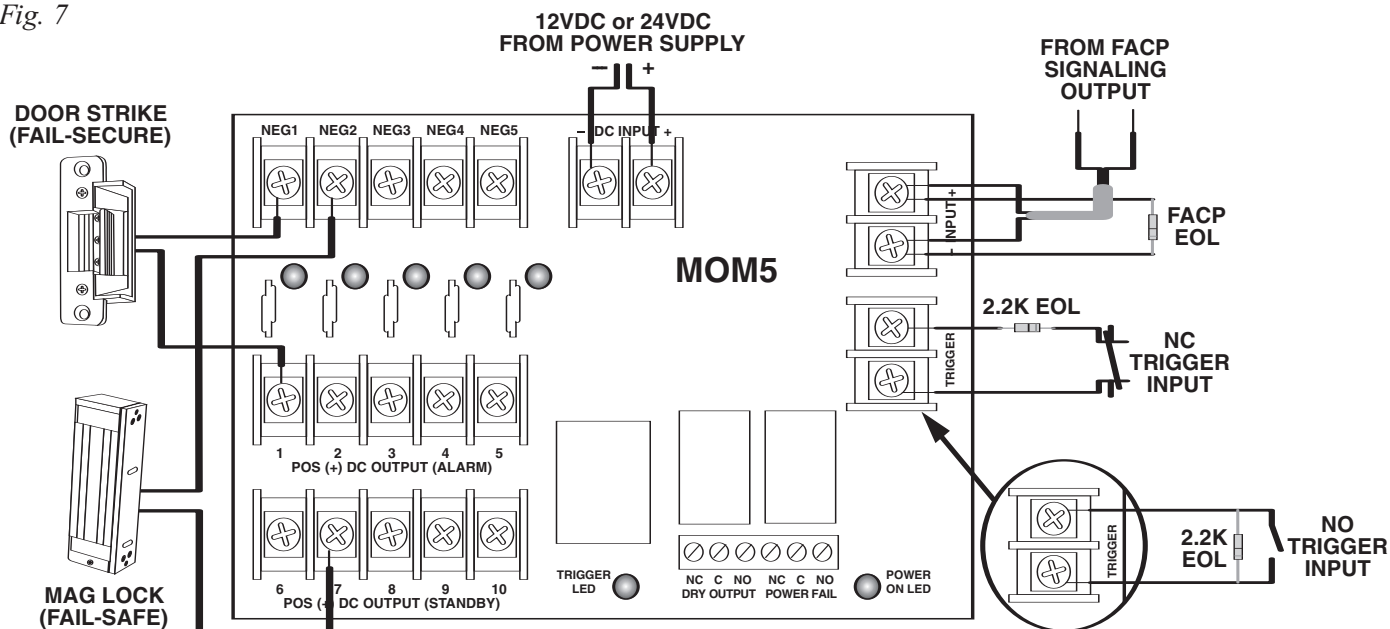

Fig. 7



Altronix is not responsible for any typographical errors.

