

Video • Data

HubWay[®]LDH[™]



Active UTP Transceiver Hub

Installation Guide

Models Include:

HubWayLDH8S

- Eight (8) Camera Channels



Overview:

Altronix HubWayLDH8S Active UTP Transceiver Hub transmits UTP video and RS422/RS485 data over a single CAT-5 or higher structured cable. Unit provides for 8 camera channels in a space saving 1U EIA 19" rack mount chassis which may be rack, wall or shelf mounted. Video transmission range is up to 3000 ft. max. per channel. Units are compatible with fixed or PTZ cameras. An optional HubSat4/4D Passive UTP Transceiver Hub with Integral Camera Power can be used as an accessory module to transmit video from up to 4 cameras over a single CAT-5 or higher structured cable back to the HubWayLDH8S. In addition, the HubSat4/4D provides power to these cameras locally to eliminate the possibility of voltage drop associated with long cable runs.

HubWayLDH8S Specifications:

Input:

- 115VAC 50/60Hz, 2 amp or 230VAC 50/60Hz, 1.25 amp.
- Primary fuse (internal) is rated at 5 amp/250V.

Video:

- Eight (8) channels of video over twisted pair up to 3000 ft.
- Eight (8) 75 ohm video outputs.

Data:

- RS422/RS485 data inputs.

Visual Indicators:

- AC input power indicator.
- Eight (8) video signal LED indicators.

Features:

- Picture and Gain control.
- Illuminated master power disconnect circuit breaker with manual reset.
- IEC 320 - 3-wire grounded line cord (detachable).
- Unit can be rack, wall or shelf mounted.
- 1U rack mount chassis for use in standard EIA 19" rack.

Accessories:

- Optional HubSat4/4D allows transmission of up to four (4) video signals over a single CAT-5 or higher structured cable.

Installation Instructions:

1. Set the input voltage selector switch located on the left side of the HubWayLDH8S unit for 115VAC or 230VAC operation (*Fig. 1j, pg. 3*).
2. Attach mounting brackets to HubWay unit for rack or wall mount installation (*Figs. 5-6, pg. 7*). Affix rubber pads to HubWay for shelf installation (*Fig. 7, pg. 7*).
3. Secure the unit in a rack, mount unit to a wall or place unit on a shelf as desired (unit should be spaced at least 3" from any video monitors).
4. Set illuminated master power disconnect circuit breaker to the (OFF) position (*Fig. 4, pg. 6*).
5. Plug the grounded AC line cord (included) into the IEC 320 connector of the HubWayLDH8S unit (*Fig. 1f, pg. 3*). Insert the plug end of the line cord into a grounded AC receptacle.
6. Connect the BNC video outputs for HubWayLDH8S Channels 1 - 8 to the corresponding video inputs on the head end equipment (DVR) (*Fig. 1a, pg. 3*).
7. Connect the RS422/RS485 output of the head end equipment (DVR) to the two (2) data input terminal blocks of the HubWayLDH8S unit (polarity must be observed) (*Fig. 1e, pg. 3*).
Note: The Data input terminals of the HubWayLDH8S must be connected in parallel for proper operation. When using fixed cameras disregard this step.
8. Connect Video Balun/Combiner at camera 1 to the HubWayLDH8S unit utilizing CAT-5 or higher structured cable. Plug the RJ45 connector at one end of the structured cable into the RJ45 jack marked [Channel 1] of the HubWayLDH8S (*Fig. 1g, pg. 3*). Plug the RJ45 connector at the opposite end of the structured cable into the RJ45 jack of the Video Balun/Combiner installed at camera 1.
Repeat steps 6-8 for each additional camera (Channels 2-8).
Note: An external power source is required to power the cameras (*Figs. 2-3, pgs. 4-5*). Optionally, an Altronix HubSat4/4D Passive UTP Transceiver Hub with Integral Camera Power may be utilized (*Fig. 2a, pg. 4*). The combined total cable distance must not exceed 3000 ft. for video transmission between the HubWayLDH8S and each camera routed through the HubSat4/4D.
9. Upon completion of wiring set illuminated master power disconnect circuit breaker to the RESET (ON) position (*Fig. 4, pg. 6*).
10. The video signal indicator LEDs (Red) for Channels 1-8 of the HubWayLDH8S unit will illuminate when video signal is present (*Fig. 1i, pg. 3*). If any of these LEDs are not illuminated, there is no video signal for that corresponding channel.
11. Optimize the picture quality for Channels 1-8 by adjusting the corresponding potentiometer marked [Picture] (*Fig. 1c, pg. 3*).
12. Set gain for Channels 1-8 by adjusting the corresponding potentiometer marked [Gain] (*Fig. 1d, pg. 3*).

Fig. 1

1b - Channels 1-4 & Channels 5-8:

CAT-5 or higher structured cable(s) from optional HubSat4/4D provides video transmission from up to four (4) cameras each.

1c - Picture:
Adjusts video quality.

1a - BNC Connector: Video outputs to head end equipment (DVR).

1d - Gain:
Regulates the output video and sync levels.

1f - IEC 320 Connector:
115VAC/230VAC
50/60Hz (grounded line cord included).

1g - Channels 1-8: CAT-5 or higher structured cable to Video/Balun Combiners at cameras 1-8.

1i - LED(s) 1-8:
Video signal indicators.

1h - Data: CAT-5 or higher structured cable from optional HubSat4/4D for PTZ control.

1j - Input Voltage Switch:
Selects 115VAC/230VAC
50/60Hz (switch is located on the left side of the unit).

1e - Data: Removable terminal blocks for RS422/RS485 input from head end equipment (DVR) for PTZ control.

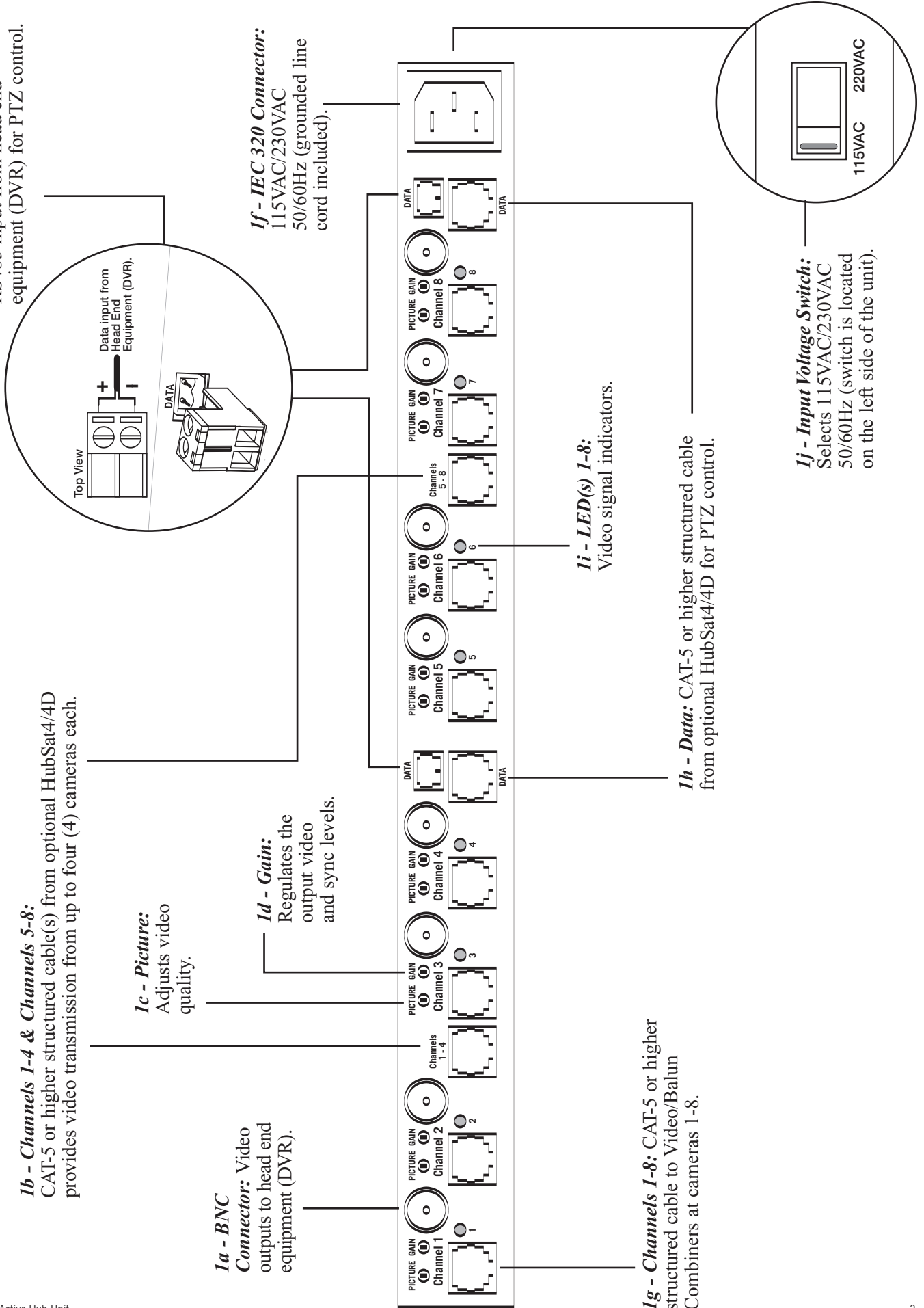

Typical Applications:

Fig. 2

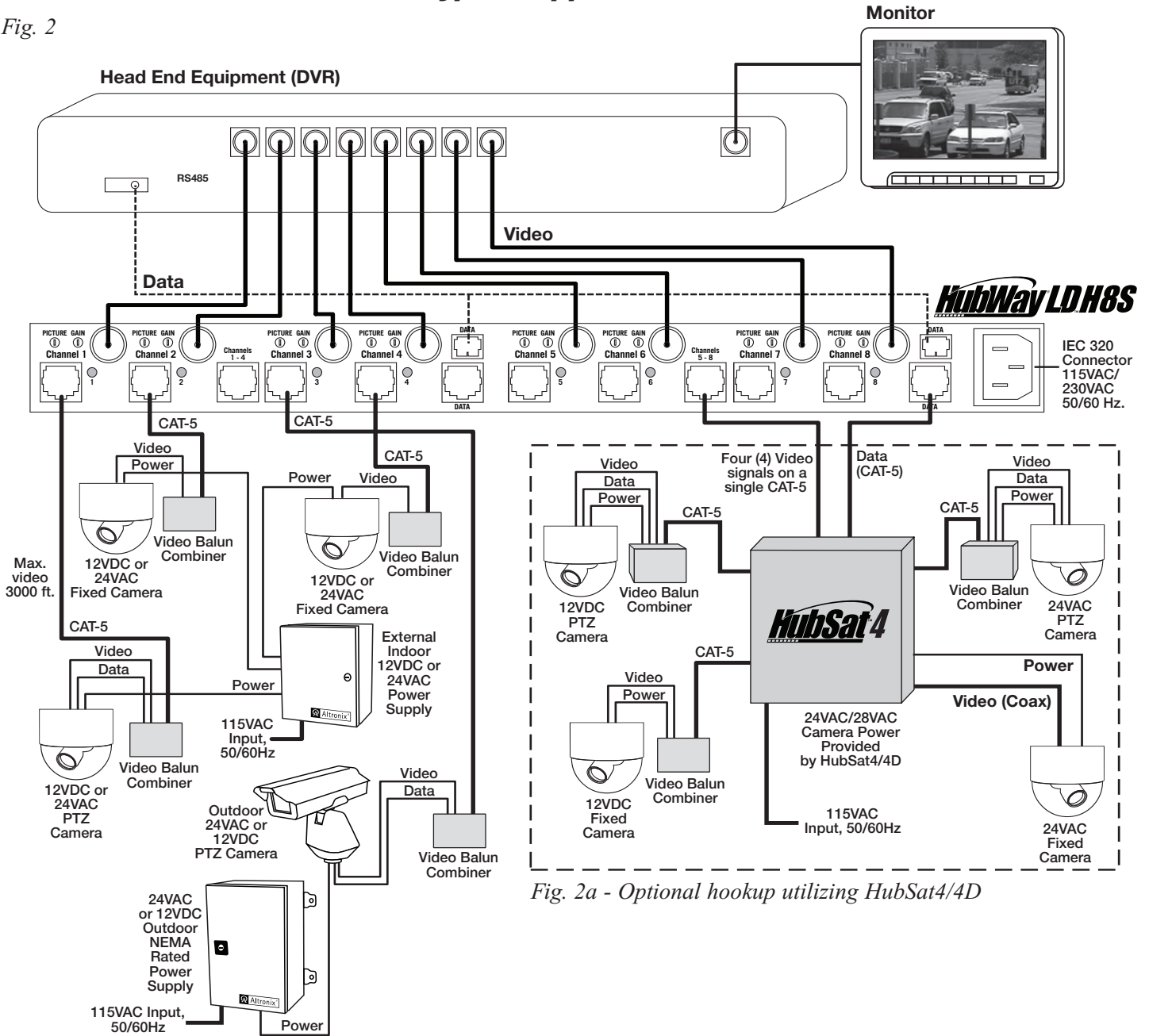
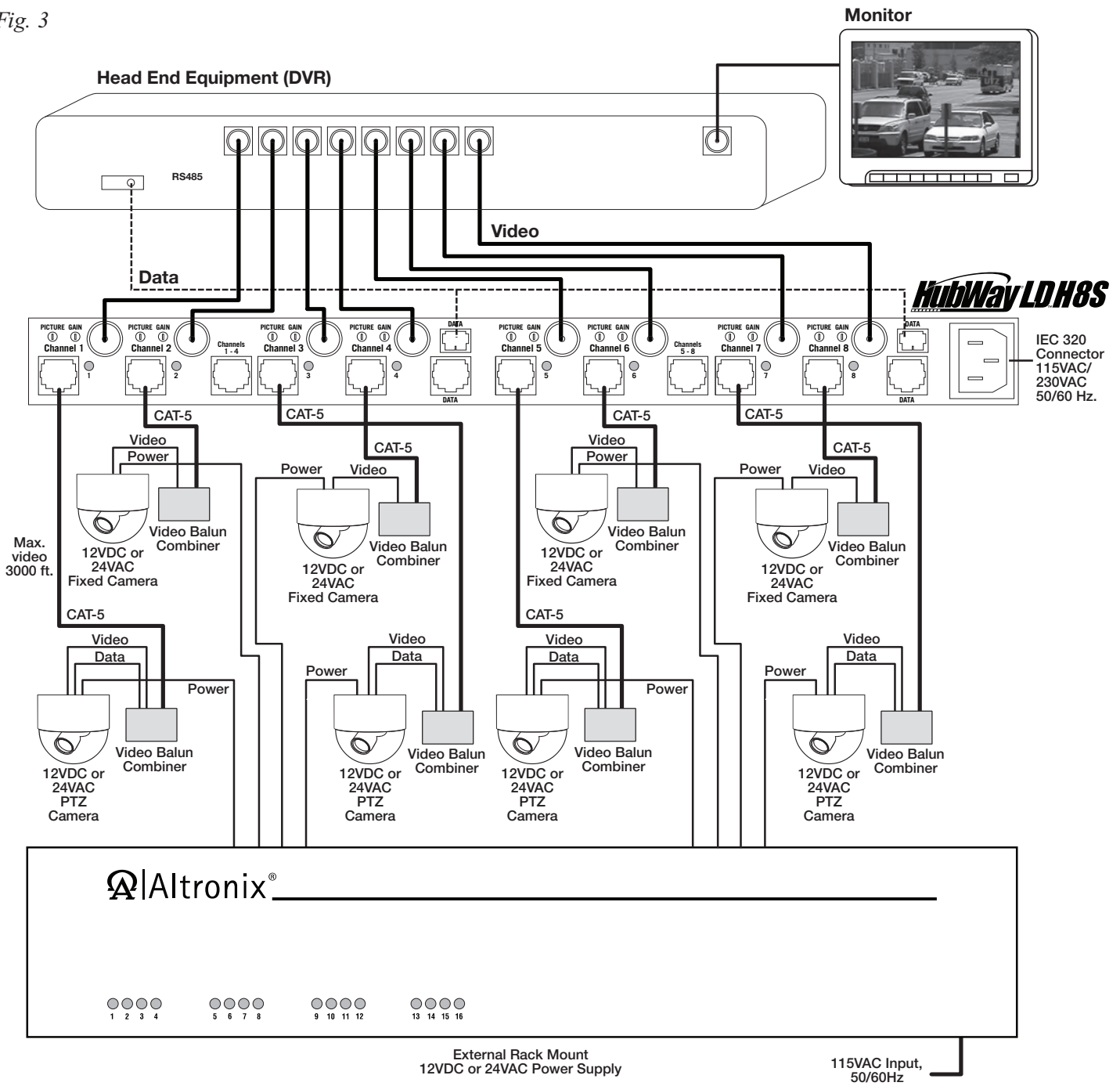

Fig. 2a - Optional hookup utilizing HubSat4/4D

Typical Application:

Fig. 3



1U Rack Mount Chassis Mechanical Drawing & Dimensions:

1.625”H x 19.125”W x 8.5”D

REAR

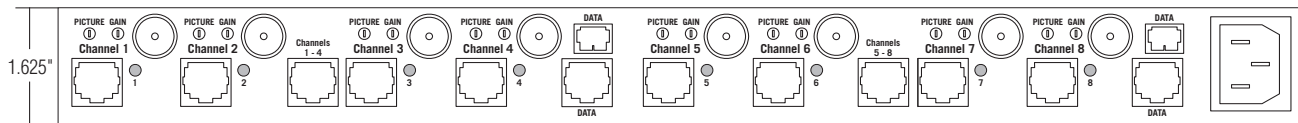

TOP & BOTTOM



FRONT

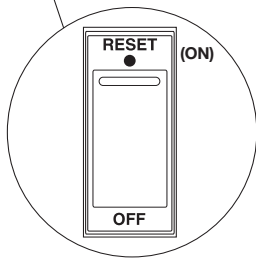
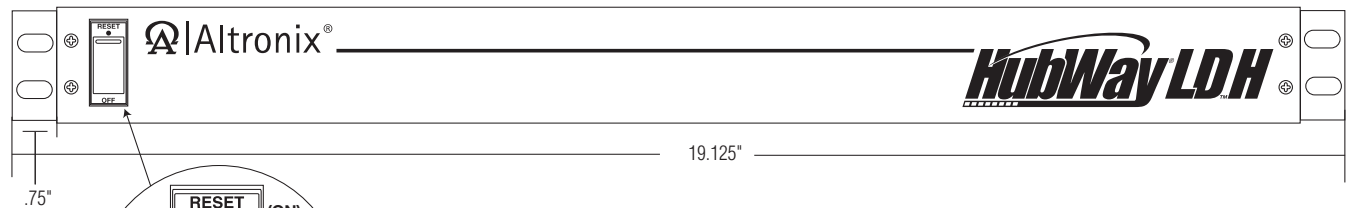

Fig. 4

Illuminated master power disconnect circuit breaker:

- OFF position Circuit breaker tripped – Switch not illuminated.
- RESET (ON) position – Switch illuminated.



The lightning flash with arrow head symbol within an equilateral triangle is intended to alert the user to the presence of an insulated “DANGEROUS VOLTAGE” within the products enclosure that may be of sufficient magnitude to constitute an electric shock.



The exclamation point within an equilateral triangle is intended to alert the user to the presence of important operating and maintenance (servicing) instructions in the literature accompanying the appliance.



CAUTION
RISK OF ELECTRIC SHOCK
DO NOT OPEN



CAUTION: To reduce the risk of electric shock do not open enclosure. There are no user serviceable parts inside. Refer servicing to qualified service personnel.

Mounting Options:

Rack Mount Installation

- 1- Remove and discard factory installed screws from both sides of rack chassis (Fig. 6a).
- 2- Install mounting brackets (A) on the left and right side of rack chassis using the four (4) flat head screws (B) (included) (Fig. 6b).
- 3- Place unit into desired EIA 19" rack position and secure with mounting screws (not included) (Fig. 6c).

Fig. 6

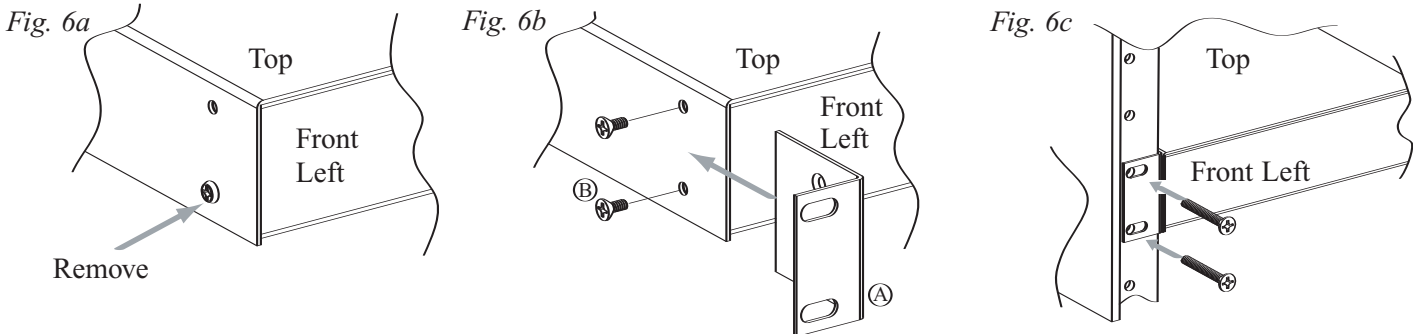

Wall Mount Installation

- 1- Install mounting brackets (A) on the left and right side of rack chassis using four (4) flat head screws (B) (included) (Fig. 7a).
- 2- Place unit at desired location and secure with mounting screws (not included) (Fig. 7b).

Caution: It is necessary to make sure mounting screws are securely fastened to a beam when installing the unit vertically.

Fig. 7

Fig. 7a

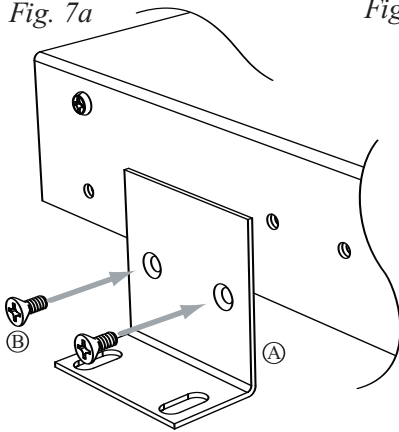
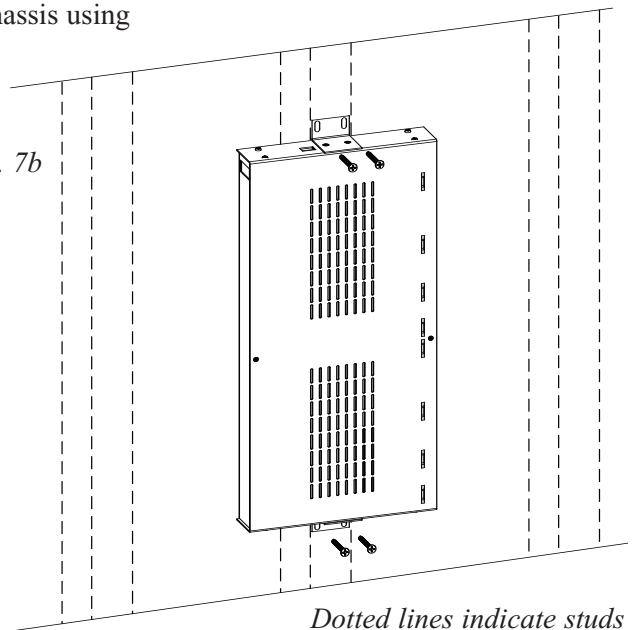

Fig. 7b



Dotted lines indicate studs behind sheetrock.



Shelf Installation

- 1- Position and affix rubber pads (C) (included) at each corner on the bottom of the unit (Fig. 8).
- 2- Place unit in desired location.

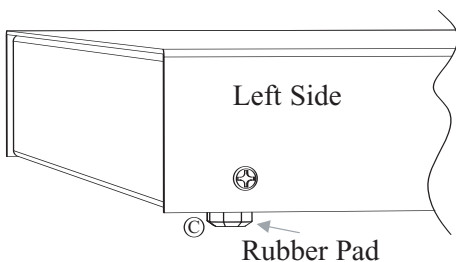
Fig. 8

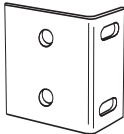

Mounting Hardware (Included):

	(A) Two (2) mounting brackets
	(B) Six (6) flat head screws for mounting brackets.
	(C) Four (4) rubber pads.

Notes:

Altronix is not responsible for any typographical errors.

140 58th Street, Brooklyn, New York 11220 USA, 718-567-8181, fax: 718-567-9056
website: www.altronix.com, e-mail: info@altronix.com, Lifetime Warranty, Made in U.S.A.
IIHubWayLDH8S F13H

