

Video • Data • Power

HubWay®



**Passive UTP Transceiver Hub
with Integral Isolated Camera Power**

Installation Guide

Models Include:

HubWay8Di

- Eight (8) Camera Channels

HubWay82Di

- HubWay8Di w/eight (8) HubWayAv
Video Balun/Combiners for 24VAC Cameras

HubWay83Di

- HubWay8Di w/eight (8) HubWayDv
Video Balun/Combiners for 12VDC Cameras

HubWay16Di

- Sixteen (16) Camera Channels

HubWay162Di

- HubWay16Di w/sixteen (16) HubWayAv
Video Balun/Combiners for 24VAC Cameras

HubWay163Di

- HubWay16Di w/sixteen (16) HubWayDv
Video Balun/Combiners for 12VDC Cameras

Overview:

Altronix HubWay8Di/16Di Passive UTP Transceiver Hub w/Integral Isolated Camera Power transmits UTP video, RS422/RS485 data and power over a single CAT-5 or higher structured cable. Unit provides 8 or 16 camera channels in a space saving 1U EIA 19" rack mount chassis which may be rack, wall or shelf mounted. Video transmission range is up to 750 ft. max. per channel. Units are compatible with AC and/or DC fixed or PTZ cameras when utilizing Altronix HubWayAv or HubWayDv Video Balun/Combiners. In addition, the unit features individually selectable 24VAC or 28VAC electronically isolated PTC protected outputs with surge suppression. An optional HubSat4i/4Di Passive UTP Transceiver Hub with Integral Camera Power can be used as an accessory module to transmit video from up to 4 cameras over a single CAT-5 or higher structured cable back to the HubWay8Di/16Di. In addition, the HubSat4i/4Di provides power to these cameras locally to eliminate the possibility of voltage drop associated with long cable runs.

HubWay Specifications:

HubWay8Di/82Di/83Di

Input:

- 115VAC 50/60Hz, 2 amp or 230VAC 50/60Hz, 1.25 amp.
- Primary fuse (internal) is rated at 5 amp/250V.

Video:

- Eight (8) channels of video over twisted pair up to a distance of 750 ft. per channel.
- Eight (8) 75 ohm video outputs.

Power:

- Unit provides up to 1 amp max. per channel not to exceed a total of 8 amp maximum current.

HubWay16Di/162Di/163Di

Input:

- 115VAC 50/60Hz, 4 amp or 230VAC 50/60Hz, 2.5 amp.
- Primary fuse (internal) is rated at 5 amp/250V.

Video:

- Sixteen (16) channels of video over twisted pair up to a distance of 750 ft. per channel.
- Sixteen (16) 75 ohm video outputs.

Power:

- Unit provides up to 1 amp max. per channel not to exceed a total of 16 amp maximum current.

Common Specifications:

Data:

- RS422/RS485 data inputs.

Power:

- Individually selectable 24VAC or 28VAC power outputs with OFF position.
- Individual electronically isolated PTC protected outputs.
- PTCs are rated @ 1 amp per channel.
- Surge suppression.

Visual Indicators:

- AC input power indicator.
- Video signal and power LED indicators.

Additional Models:

HubWay82Di

- HubWay8Di includes eight (8) HubWayAv Video Balun/Combiners for 24VAC Cameras.

HubWay83Di

- HubWay8Di includes eight (8) HubWayDv Video Balun/Combiners for 12VDC Cameras.

Features:

- Illuminated master power disconnect circuit breaker with manual reset.
- IEC 320 - 3-wire grounded line cord (detachable).
- Unit can be rack, wall or shelf mounted.
- 1U rack mount chassis for use in standard EIA 19" rack.

Accessories:

- Video Balun/Combiners:
 - HubWayAv - for use with 24VAC cameras.
 - HubWayDv - for use with 12VDC cameras.
- Optional HubSat4i/4Di allows transmission of up to four (4) video signals over a single CAT-5 or higher structured cable.

HubWay162Di

- HubWay16Di includes sixteen (16) HubWayAv Video Balun/Combiners for 24VAC Cameras.

HubWay163Di

- HubWay16Di includes sixteen (16) HubWayDv Video Balun/Combiners for 12VDC Cameras.

Installation Instructions:

1. Set the input voltage selector switch located on the left side of the HubWay8Di/16Di unit (facing front panel) for 115VAC or 230VAC operation (*Fig. 1i, pg. 4*).
2. Attach mounting brackets to HubWay unit for rack or wall mount installation (*Figs. 6-7, pg. 8*). Affix rubber pads to HubWay for shelf installation (*Fig. 8, pg. 8*).
3. Secure the unit in a rack, mount unit to a wall or place unit on a shelf as desired (unit should be spaced at least 3" from any video monitors).
4. Set illuminated master power disconnect circuit breaker to the (OFF) position (*Fig. 5, pg. 7*).

5. Plug the grounded AC line cord (included) into the IEC 320 connector of the HubWay8Di/HubWay16Di unit (*Fig. 1h, pg. 4*). Insert the plug end of the line cord into a grounded AC receptacle.
6. Select 24VAC or 28VAC power output for Channels 1-8 (Channels 1-16) with the corresponding voltage adjustment switches (*Fig. 1d, pg. 4*).
7. Connect the BNC video outputs for HubWay8Di/16Di Channels 1 - 8 (Channels 1-16) to the corresponding video inputs on the head end equipment (DVR) (*Fig. 1f, pg. 4*).
8. Connect the RS422/RS485 output of the head end equipment (DVR) to the one (1) or both data input terminal blocks of the HubWay8Di or HubWay16Di unit (polarity must be observed) (*Fig. 1e, pg. 4*).
Note: The Data input terminals of the HubWay8Di or HubWay16Di must be wired in parallel for proper operation. When using fixed cameras disregard this step.
9. Connect Video Balun/Combiner at camera 1 to the HubWay8Di or HubWay16Di unit utilizing CAT-5 or higher structured cable. Plug the RJ45 connector at one end of the structured cable into the RJ45 jack marked [Channel 1] of the HubWay8Di/16Di (*Fig. 1a, pg. 4*). Plug the RJ45 connector at the opposite end of the structured cable into the RJ45 jack of the Video Balun/Combiner located at camera 1.
 - For 24VAC cameras use Altronix model HubWayAv Video Balun/Combiner (*Figs. 2a, 2b, pg. 5*).
 - For 12VDC cameras use Altronix model HubWayDv Video Balun/Combiner (*Figs. 2c, 2d, pg. 5*).
 Repeat steps 6-9 for each additional camera (Channels 2-8 or Channels 2-16).
Note: When a particular camera exceeds the maximum distance for power transmission, a local external power source is required. Optionally, an Altronix HubSat4i/4Di Passive UTP Transceiver Hub with Integral Camera Power may be utilized (*Fig. 4a, pg. 6*).
 The combined total cable distance must not exceed 750 ft. for video transmission between the HubWay8Di/16Di and each camera routed through the HubSat4i/4Di.
10. Set illuminated master power disconnect circuit breaker to the RESET (ON) position (*Fig. 5, pg. 7*) and measure the output voltage at the power output of each Video Balun/Combiner (*Figs. 2b, 2d, pg. 5*) before powering each camera to insure proper operation and avoid possible damage.
 - HubWayAv - Terminals marked [AC POWER] (*Figs. 2a, 2b, pg. 5*).
 - HubWayDv - Terminals marked [- 12VDC +] (*Figs. 2c, 2d, pg. 5*).
11. Set illuminated master power disconnect circuit breaker to the (OFF) position to make the final connections (*Fig. 5, pg. 7*).
12. Connect the power outputs of the HubWayAv or HubWayDv Video Balun/Combiners to the power inputs of the cameras (*Figs. 2a-2d, pg. 5*). Polarity must be observed.
13. Connect the terminals marked [+ DATA -] of the HubWayAv or HubWayDv Video Balun/Combiners to the data terminals of the cameras for PTZ control (*Figs. 2a-2d, pg. 5*). Polarity must be observed.
 When using fixed cameras disregard this step.
14. Connect the BNC connector of the HubWayAv or HubWayDv Video Balun/Combiners to the BNC video outputs of the cameras (*Figs. 2a-2d, pg. 5*).
15. Upon completion of wiring set illuminated master power disconnect circuit breaker to the RESET (ON) position (*Fig. 5, pg. 7*).
16. AC LED (Green) of the HubWayAv or DC LED (Red) of the HubWayDv Video Balun/Combiners will illuminate indicating power is present at the cameras (*Fig. 2b, 2d, pg. 5*).
17. The power LEDs (Red) located beneath the blade fuses for Channels 1-8 (Channels 1-16) of the HubWay8Di/16Di will illuminate when AC power is present (*Fig. 1c, pg. 4*). If all of the LEDs are OFF there may be a complete loss of supply power to the HubWay unit or the illuminated master power disconnect circuit breaker is in the OFF position.

To restore the power output for HubWay8Di/16Di:

The PTC for that particular output is tripped.

- 1- Switch output voltage switch to the OFF position (*Fig. 1d, pg. 4*) to reset the PTC allowing approximately 1 minute before switching back to 24VAC or 28VAC.
- 2- Eliminate the trouble condition.
- 3- Switch output voltage switch back to the 24VAC or 28VAC position (*Fig. 1d, pg. 4*).

Fig. 1

1a - Channels 1-4, Channels 5-8, Channels 9-12 & Channels 13-16:
 CAT-5 or higher structured cable from optional HubSat4i/4Di enables video transmission from up to four (4) cameras.

1a - Channels 1-8 (HubWay8Di) or Channels 1-16 (HubWay16Di):
 CAT-5 or higher structured cable to Video/Balun Combiners at cameras 1-8 or 1-16. When using the optional HubSat4i/4Di any of the outputs can be utilized for the data transmission from the HubSat4i/4Di.

1c - LED(s) 1-16:
 Power indicators.

1d - Output voltage switches: Selects 24VAC/28VAC/OFF for each output.

1e - Data: Removable terminal blocks for RS422/RS485 input from head end equipment (DVR) for PTZ control.

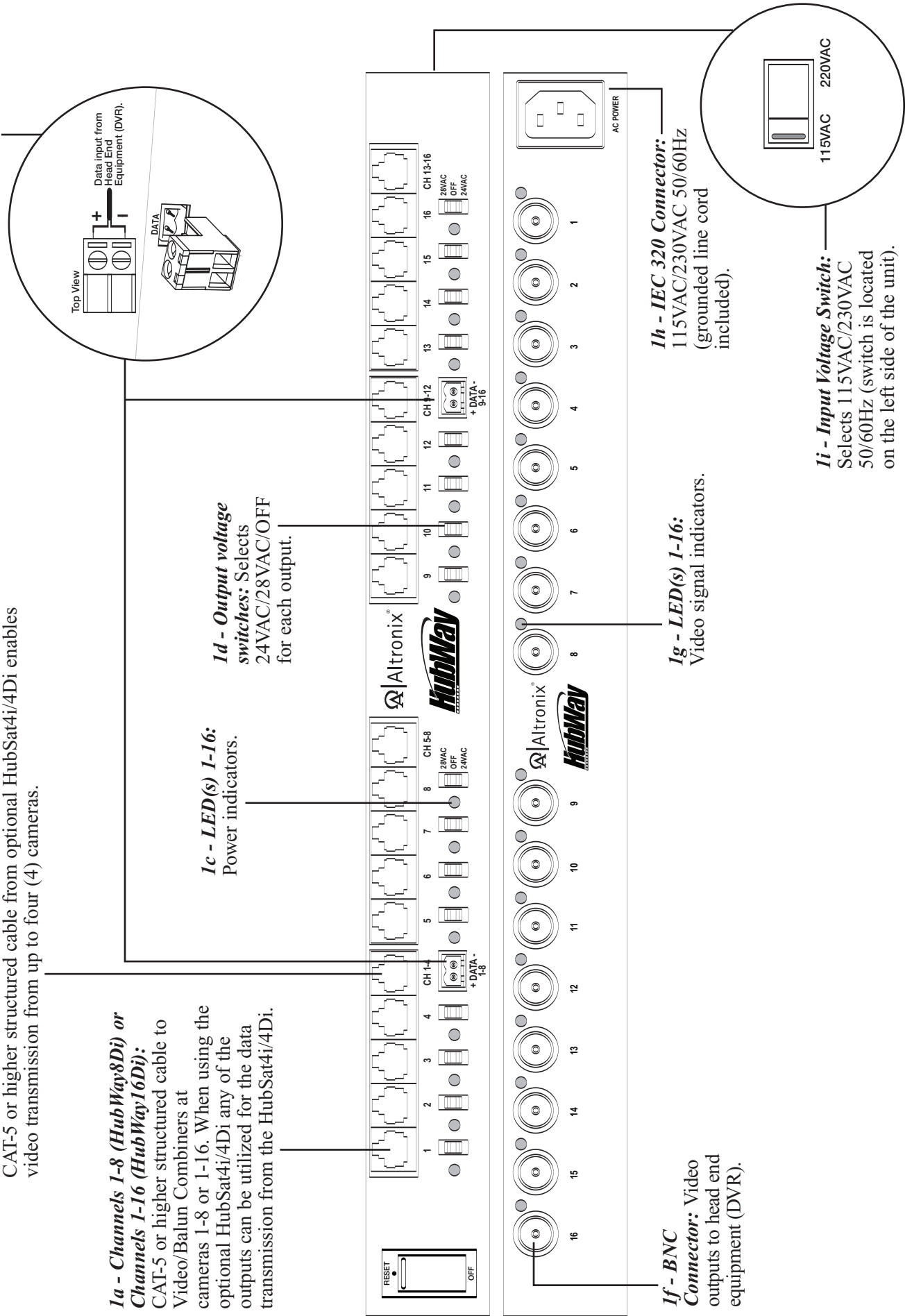

1f - BNC Connector: Video outputs to head end equipment (DVR).

1g - LED(s) 1-16:
 Video signal indicators.

1h - IEC 320 Connector:
 115VAC/230VAC 50/60Hz (grounded line cord included).

1i - Input Voltage Switch:
 Selects 115VAC/230VAC 50/60Hz (switch is located on the left side of the unit).

HubWayAv and HubWayDv Video Balun/Combiners:

Altronix Model Number	Input Voltage from HubWay unit	Output Voltage to camera	Camera Type	Power LED
HubWayAv	*24VAC/28VAC	*24VAC/28VAC	24VAC cameras	Green
HubWayDv	*24VAC/28VAC	12VDC	12VDC cameras	Red

*Based on camera load and structured cable length.

Fig. 2

Fig. 2a

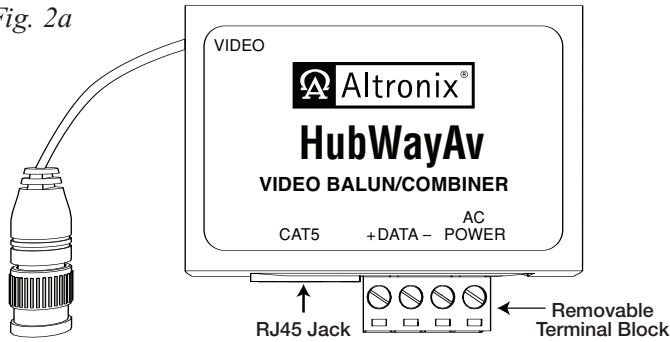

Fig. 2c

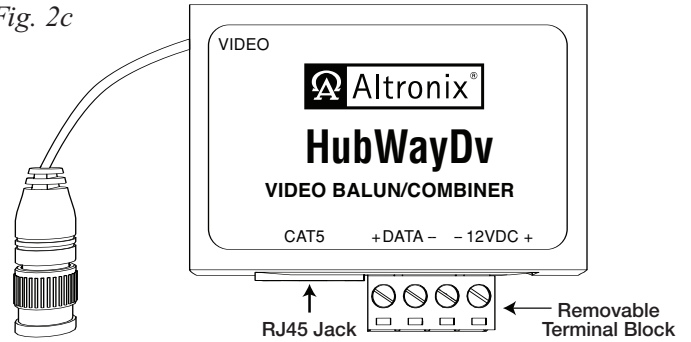

Fig. 2b

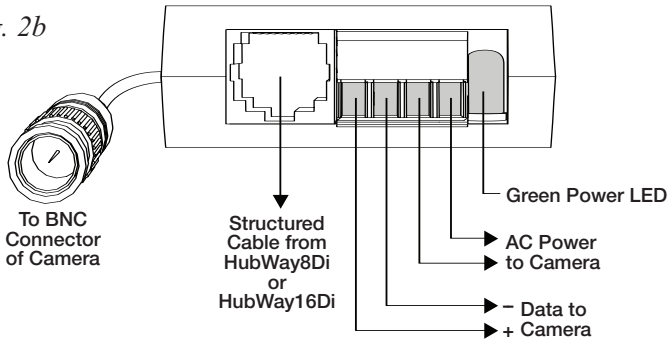
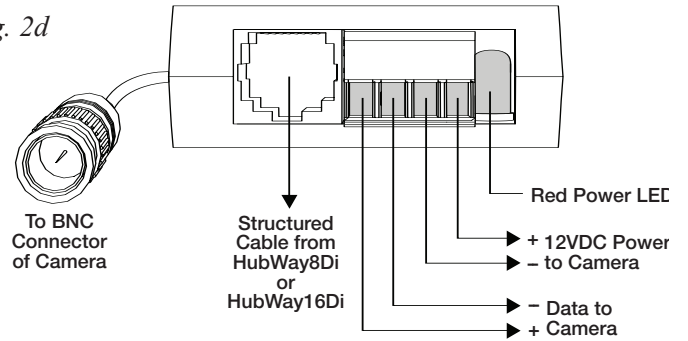

Fig. 2d



HubWayAv passes AC voltage from pins 4, 5, 7, 8 to terminals marked [AC Power] (Fig. 3, pg. 5).

HubWayDv converts AC voltage to DC voltage from pins 4, 5, 7, 8 to terminals marked [- 12VDC +] (Fig. 3, pg. 5).

Fig. 3 - CAT-5 Structured Cable Wiring Color Codes and PIN Configurations

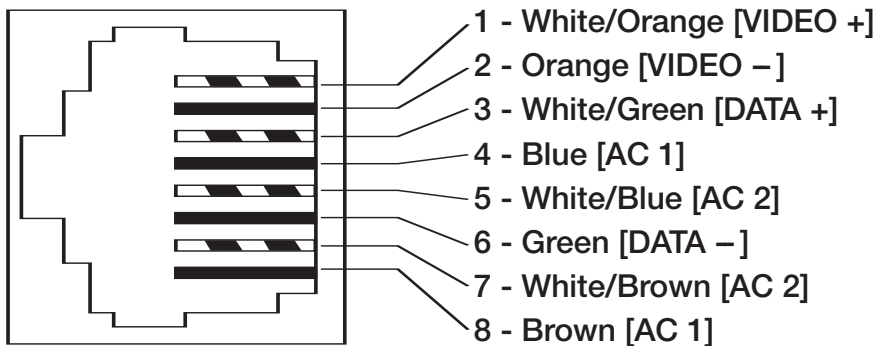

Typical Applications:

Fig. 4

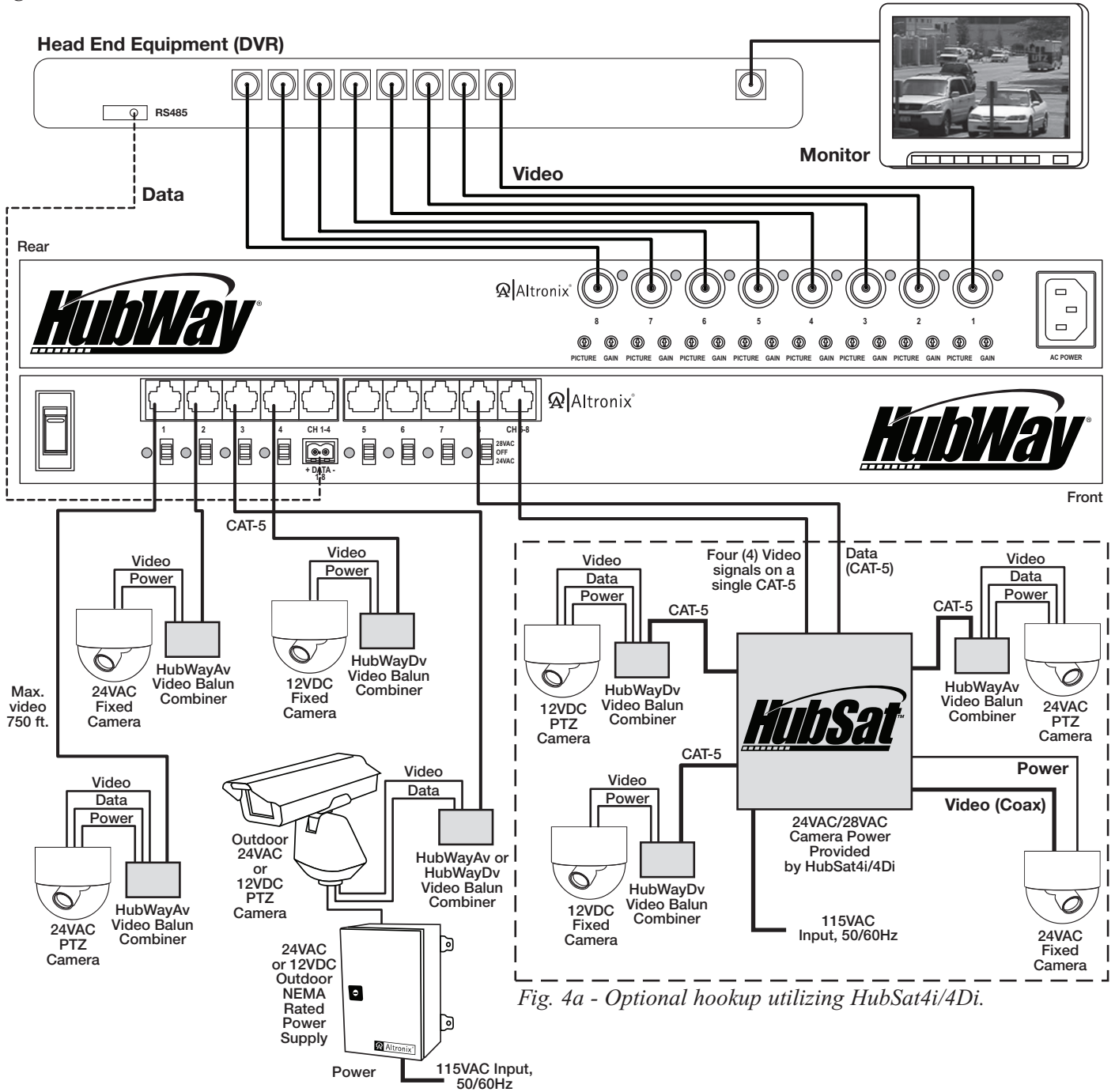
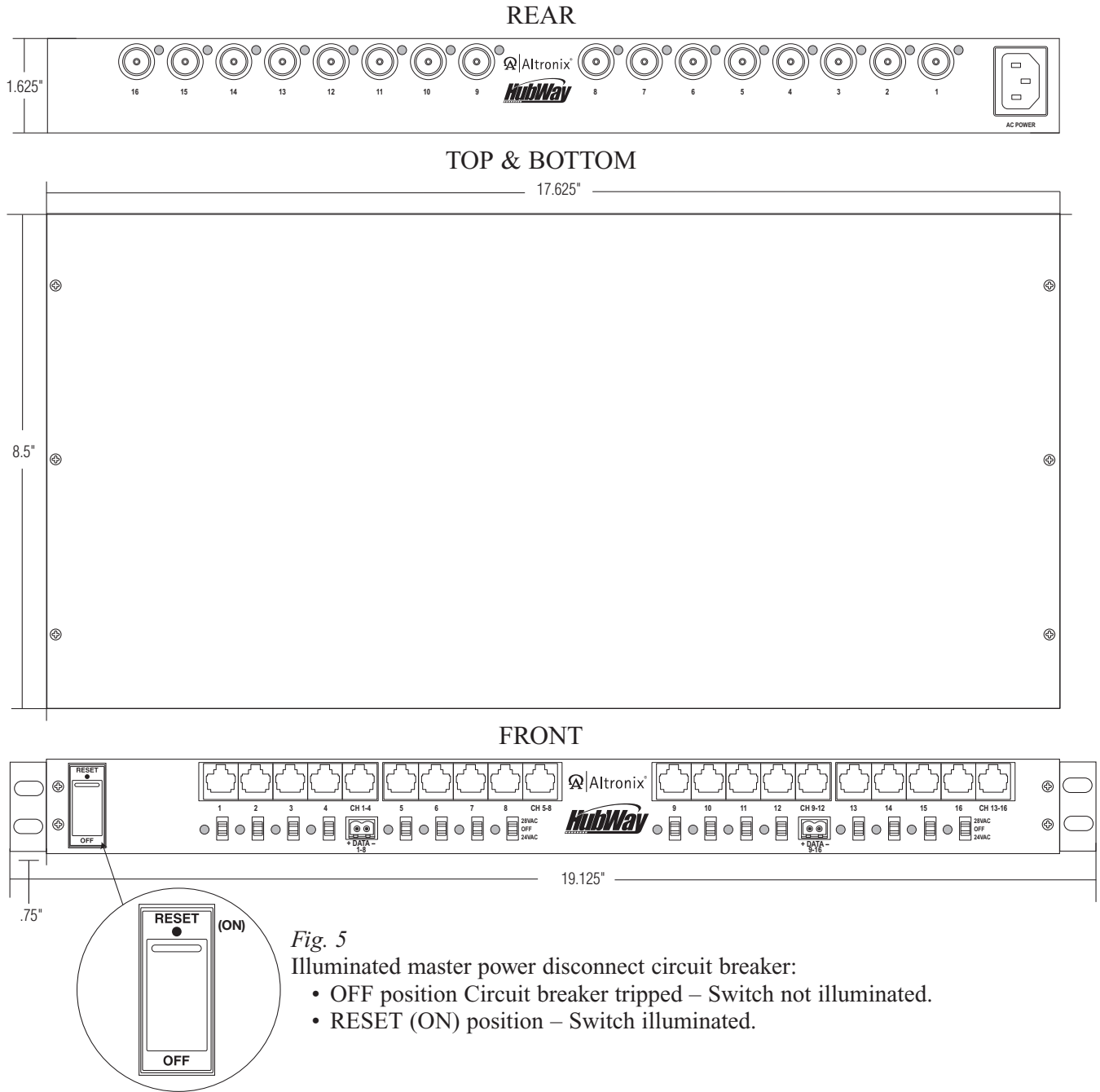

Fig. 4a - Optional hookup utilizing HubSat4i/4Di.

1U EIA 19" Rack Mount Chassis Mechanical Drawing & Dimensions:

1.625"H x 19.125"W x 8.5"D



The lightning flash with arrow head symbol within an equilateral triangle is intended to alert the user to the presence of an insulated "DANGEROUS VOLTAGE" within the products enclosure that may be of sufficient magnitude to constitute an electric shock.



The exclamation point within an equilateral triangle is intended to alert the user to the presence of important operating and maintenance (servicing) instructions in the literature accompanying the appliance.



CAUTION
RISK OF ELECTRIC SHOCK
DO NOT OPEN



CAUTION: To reduce the risk of electric shock do not open enclosure. There are no user serviceable parts inside. Refer servicing to qualified service personnel.

Mounting Options:

Rack Mount Installation

- 1- Remove and discard factory installed screws from both sides of rack chassis (Fig. 6a).
- 2- Install mounting brackets (A) on the left and right side of rack chassis using the four (4) flat head screws (B) (included) (Fig. 6b).
- 3- Place unit into desired EIA 19" rack position and secure with mounting screws (not included) (Fig. 6c).

Fig. 6

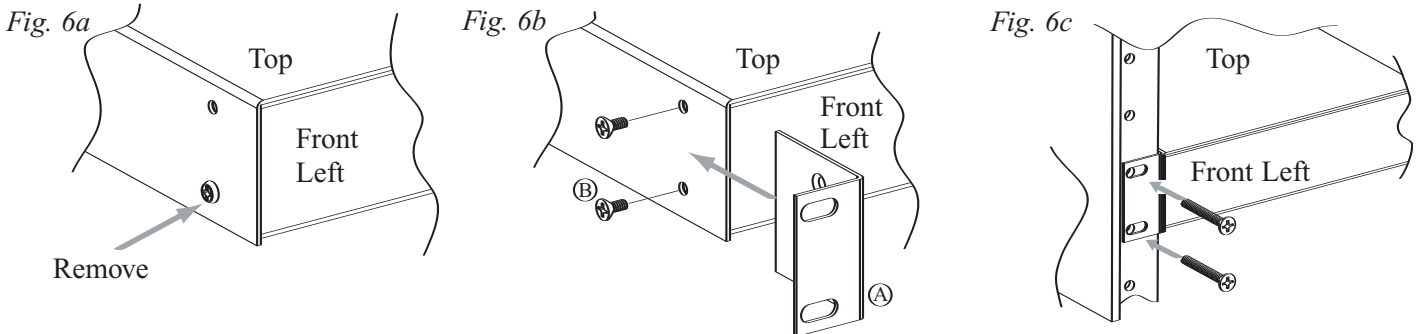

Wall Mount Installation

- 1- Install mounting brackets (A) on the left and right side of rack chassis using four (4) flat head screws (B) (included) (Fig. 7a).
- 2- Place unit at desired location and secure with mounting screws (not included) (Fig. 7b).

Caution: It is necessary to make sure mounting screws are securely fastened to a beam when installing the unit vertically.

Fig. 7

Fig. 7a

Fig. 7b

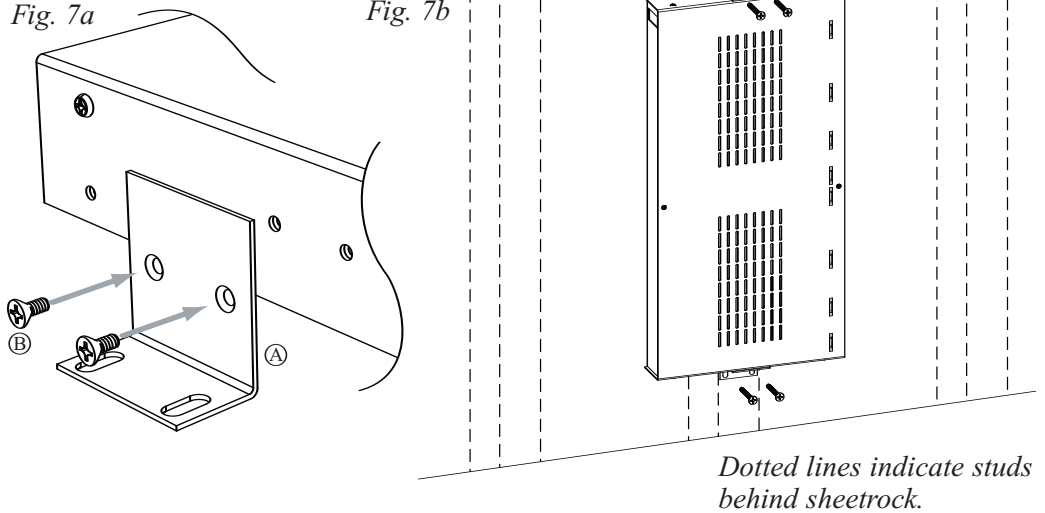

Dotted lines indicate studs behind sheetrock.

Shelf Installation

- 1- Position and affix rubber pads (C) (included) at each corner on the bottom of the unit (Fig. 8).
- 2- Place unit in desired location.

Fig. 8

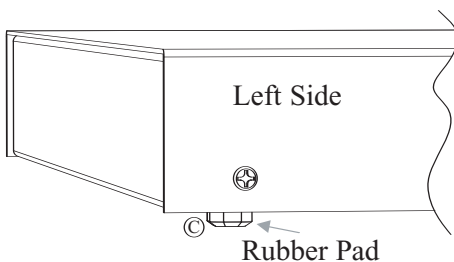

Mounting Hardware (Included):

	(A) Two (2) mounting brackets
	(B) Six (6) flat head screws for mounting brackets.
	(C) Four (4) rubber pads.

Altronix is not responsible for any typographical errors.