

Overview:

The FireSwitch16D power distribution module converts a single AC or DC input into sixteen (16) Class 2 Rated PTC protected power limited outputs. This unit also provides fire alarm interface with latching feature.

Specifications:

Input:

- 28VAC or 28VDC up to 10 amp.
- 5VDC-32VDC FACP trigger input.

Outputs:

- Sixteen (16) Class 2 Rated PTC protected power limited outputs.

PTC Ratings:

- PTCs are rated @ 2.5A/30V.

Visual Indicators:

- Power output LED indicator.

Additional Features:

- Fire alarm interface with latching.

Board Dimensions (approximate):

6"H x 5.875"W x .95"D

Installation Instructions:

1. Mount FireSwitch16D in desired location/enclosure.
2. Connect the desired power supply output to terminals marked [INPUT] (Fig. 1A). Leave "S" terminal disconnected.
3. Measure output voltage before connecting devices. This helps avoid potential damage. All terminals with common suffix P "1P, 2P..." are same polarity (positive for DC applications). All terminals with common suffix N 1N, 2N..." are same polarity (negative for DC applications).
4. Connect each device to terminal pairs 1 to 16, marked [1P-1N thru 16P - 16N].
5. To use fire alarm interface, consult typical application drawings for N.O., N.C. and wet trigger circuits (Figs. 2-5, pg. 2).

Note: Outputs will be powered down upon activation of fire alarm interface.

Fig. 1

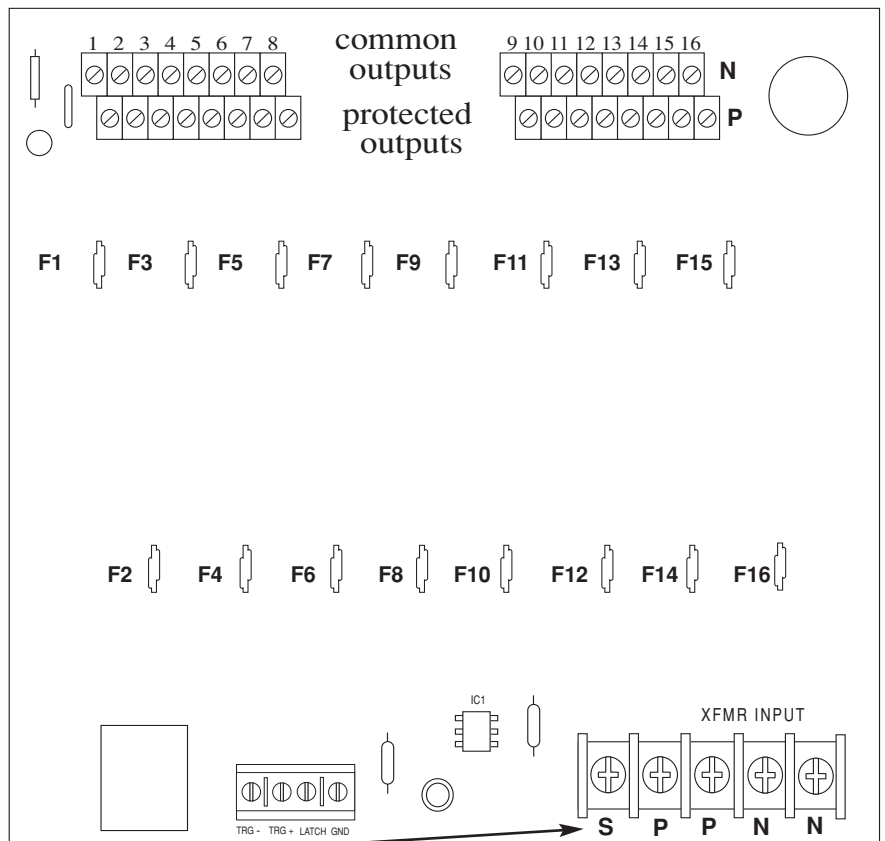
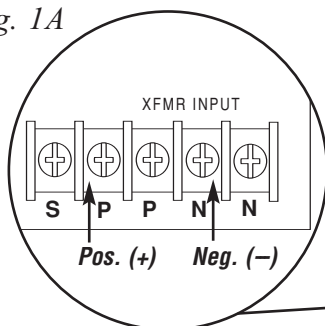

Fig. 1A



Typical Application Diagrams:

Fig. 2 FireSwitch16D module shown with wet voltage trigger.

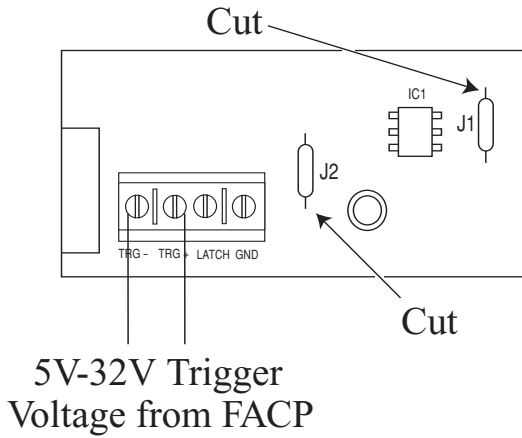

Fig. 3 FireSwitch16D module shown with N.C. Dry trigger.

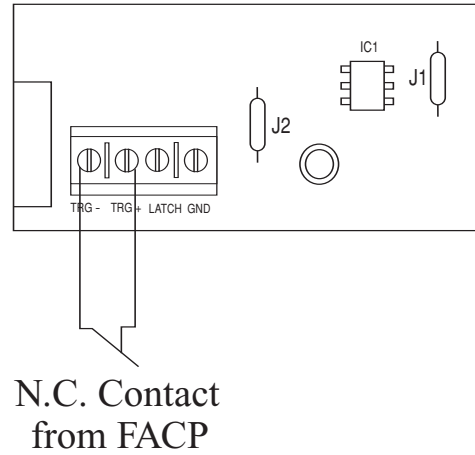

Fig. 4 FireSwitch16D module shown with N.O. Dry trigger.

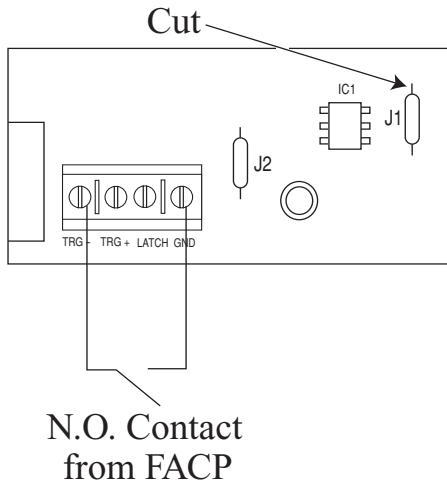
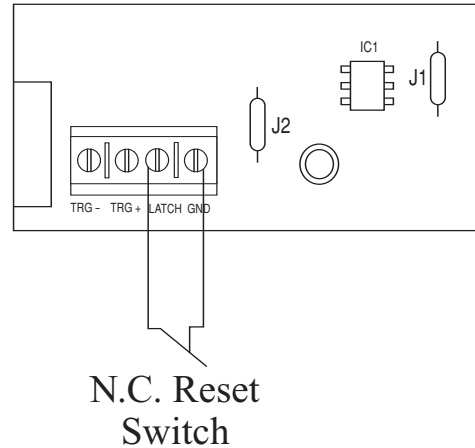

Fig. 5 FireSwitch16D module shown with Latching Mode



Altronix is not responsible for any typographical errors. Product specifications are subject to change without notice.