

Overview:

DPS5 power supply/charger converts low voltage AC input into 6VDC, 12VDC or 24VDC @ 4 amp of continuous supply current (see specifications). This general purpose power supply has a wide range of applications for access control, security and CCTV system accessories that require additional power.

Specifications:

- 6VDC-12VDC-24VDC selectable output.
- 4 amp continuous supply current at 6VDC-12VDC-24VDC*.
- Filtered and electronically regulated output.
- Built-in charger for sealed lead acid or gel type batteries.
- Maximum charge current 300mA.
- Automatic switch over to stand-by battery.
- Battery short circuit protection (circuit breaker).
- Thermal overload and short circuit protection.
- AC input and DC output LED indicators.
- Extremely compact design.
- Includes battery leads and Snap Trac (Altronix model #ST3).

Board Dimensions: 3.5”L x 2.75”W x 1.75H

* Specified at 25° C ambient.

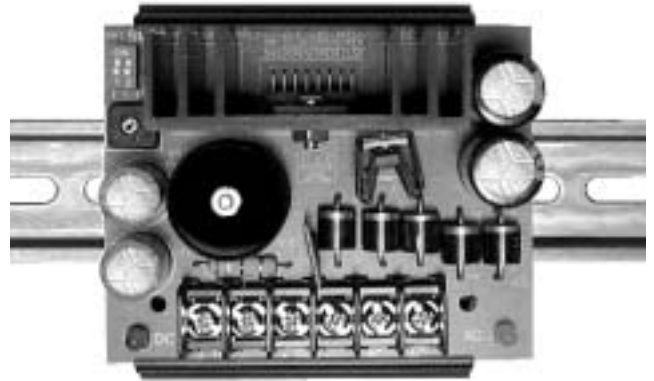

Voltage Output/Transformer Selection Table:

Output Voltage	Switch Position		Transformer Requirements (Recommended Altronix Part #'s)
	1	2	
6VDC	Closed	Open	16VAC / 40VA (TP1640)
12VDC	Open	Open	28VAC / 100VA (T2885 or T24130)
24VDC	Open	Closed	28VAC / 175VA (T28140)

Note: Transformers with higher ratings may be used for all output voltages above as long as you do not exceed 28VAC or 45VDC.

Installation Instructions:

The DPS5 should be installed in accordance with The National Electrical Code and all applicable Local Regulations.

1. Mount the DPS5 in desired location.
2. Set DC output voltage with switches (*refer to Voltage Output/Transformer Selection Table*).
3. Connect proper transformer to terminals marked [AC] (*refer to Voltage Output/Transformer Selection Table*).
Use 18 AWG or larger for all power connections (Battery, DC output).

Keep power limited wiring separate from non-power limited wiring (115VAC / 60Hz Input, Battery Wires).

Minimum .25” spacing must be provided.

4. Measure output voltage before connecting devices. This helps avoid potential damage.
5. Connect devices to be powered to terminals marked [+ DC –].
6. When the use of stand-by batteries are desired, they must be lead acid or gel type.
Connect battery to terminals marked [+ BAT –] (battery leads included).
Use two (2) 12VDC batteries connected in series for 24VDC operation.

Note: When batteries are not used a loss of AC will result in the loss of output voltage.

LED Diagnostics:

Red (DC)	Green (AC)	Power Supply Status
ON	ON	Normal operating condition.
ON	OFF	Loss of AC, Stand-by battery supplying power.
OFF	ON	No DC output. Short circuit or thermal overload condition.
OFF	OFF	No DC output. Loss of AC. Discharged or no battery present.

DPS5 - Board Drawing:

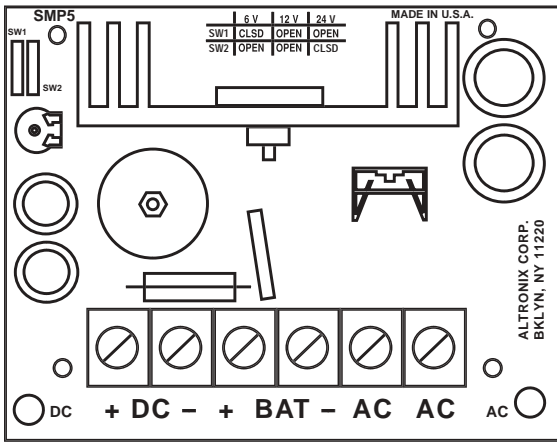

ST3 Drawing:

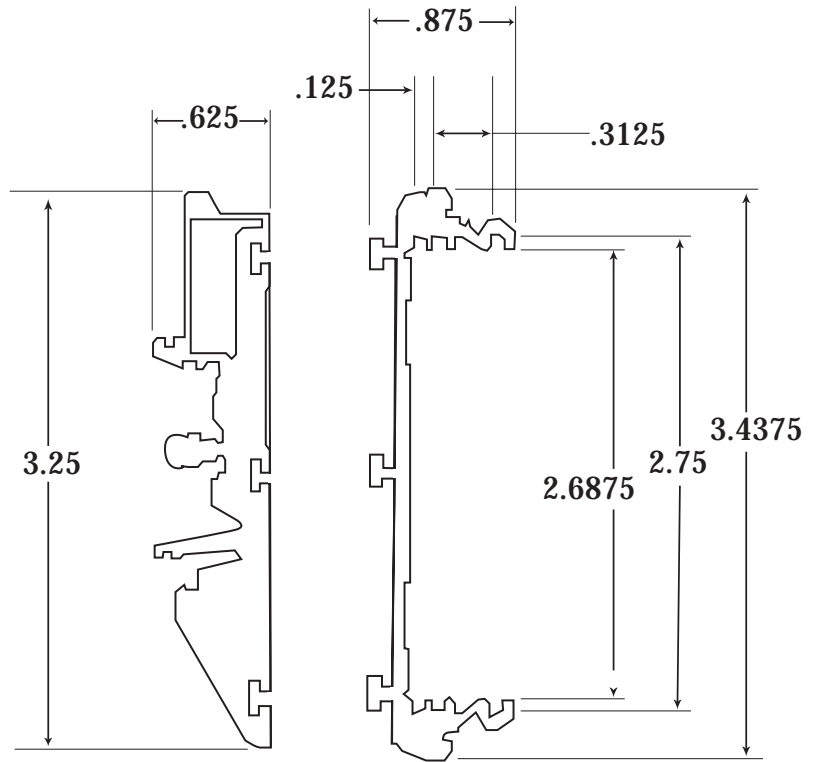

Terminal Identification:

Terminal Legend	Function/Description
AC/ AC	Low voltage AC input (<i>refer to Voltage Output/Transformer Selection Table</i>). For 6VDC output use 16VAC or higher with 40VA power rating or higher. For 12VDC output use 16VAC or higher with 85VA power rating or higher. For 24VDC output use 28VAC with 175VA power rating or higher. Caution: Do not apply voltages above 28 VAC (28VAC is maximum input rating)
+ DC -	6VDC-12VDC-24VDC @ 4 amp continuous output.
+ BAT -	Stand-by battery connections. Maximum charge rate 300mA.

Altronix is not responsible for any typographical errors. Product specifications are subject to change without notice.

