



# ***ALTV2416UL Series CCTV Power Supplies***

## ***Installation Guide***

### ***Models Include:***

- ***ALTV2416ULX***
  - ***24VAC @ 7 amp (170VA)  
or 28VAC @ 6 amp (170VA).***
  - ***Sixteen (16) Fuse Protected Outputs.***
- ***ALTV2416300UL***
  - ***24VAC @ 12.5 amp (300VA)  
or 28VAC @ 10 amp (280VA).***
  - ***Sixteen (16) Fuse Protected Outputs.***
- ***ALTV2416300ULM***
  - ***24VAC @ 12.5 amp (300VA)  
or 28VAC @ 10 amp (280VA).***
  - ***Sixteen (16) Fuse Protected Outputs.***
- ***ALTV2416600UL***
  - ***24VAC @ 25 amp (600VA)  
or 28VAC @ 20 amp (560VA).***
  - ***Sixteen (16) Fuse Protected Outputs.***
- ***ALTV2416ULCBX***
  - ***24VAC @ 7 amp (170VA)  
or 28VAC @ 6 amp (170VA).***
  - ***Sixteen (16) PTC Protected Outputs.***
- ***ALTV2416300ULCB***
  - ***24VAC @ 12.5 amp (300VA)  
or 28VAC @ 10 amp (280VA).***
  - ***Sixteen (16) PTC Protected Outputs.***
- ***ALTV2416300ULCBM***
  - ***24VAC @ 12.5 amp (300VA)  
or 28VAC @ 10 amp (280VA).***
  - ***Sixteen (16) PTC Protected Outputs.***
- ***ALTV2416600ULCB***
  - ***24VAC @ 25 amp (600VA)  
or 28VAC @ 20 amp (560VA).***
  - ***Sixteen (16) PTC Protected Outputs.***

### Overview:

These Altronix CCTV Power Supplies provide 24VAC/28VAC distributed via sixteen (16) fuse or PTC protected outputs for powering CCTV Cameras, heaters and other video accessories.

### Sixteen (16) Output ALTV2416UL Reference Chart:

Altronix Model Number	Output Voltage		Total Output Current (Power)	Number of Outputs	PTC Protected Outputs power limited for Dry locations) (Class 3 for Wet locations).	Fuse Protected Class 2 Individual Output Current (max per output not to exceed total output current)	Fuse Protected Class 1 Outputs Fuse Ratings	Main Fuse Ratings	Primary In-line Fuse Ratings	115VAC 50/60Hz Input Current	Agency Listings
	24VAC	28VAC									
ALTV2416ULX	24VAC	7 amp	16	-	Yes	3.5 amp	3.5 amp	5 amp/250V	3.5 amp/250V	1.8 amp	cUL US CE
	28VAC	6 amp									
ALTV2416ULCBX	24VAC	7 amp	16	Yes	-	2.5 amp	-	5 amp/250V	3.5 amp/250V	1.8 amp	cUL US CE
	28VAC	6 amp		-	Yes						
ALTV2416300UL	24VAC	12.5 amp	16	-	Yes	3.5 amp	3.5 amp	10 amp/250V	-	2.7 amp	cUL US CE
	28VAC	10 amp									
ALTV2416300ULCB	24VAC	12.5 amp	16	Yes	-	3.5 amp	-	10 amp/250V	-	2.7 amp	cUL US CE
	28VAC	10 amp									
ALTV2416300ULM	24VAC	12.5 amp	16	-	Yes	3.5 amp	3.5 amp	-	-	2.7 amp	cUL US CE
	28VAC	10 amp									
ALTV2416300ULCBM	24VAC	12.5 amp	16	Yes	-	2.5 amp	-	-	-	2.7 amp	cUL US CE
	28VAC	10 amp									
ALTV2416600UL	24VAC	25 amp	16	-	Yes	3.5 amp	3.5 amp	15 amp/32V	-	5.4 amp	cUL US CE
	28VAC	20 amp									
ALTV2416600ULCB	24VAC	25 amp	16	Yes	-	2.5 amp	-	15 amp/32	-	5.4 amp	cUL US CE
	28VAC	20 amp									

### Specifications:

- UL Listed for Commercial CCTV Equipment (UL 2044). CUL Listed - CSA Standard C22.2 No.1-98, Audio, Video and Similar Equipment.
- Surge suppression.
- AC power LED indicator.
- Power ON/OFF switch (ALTV2416ULX, ALTV2416ULCBX).
- Illuminated power disconnect circuit breaker with manual reset (all other models).
- Unit maintains camera synchronization.
- Ease of installation saves time & eliminates costly labor.
- Spare fuses included (on fuse protected models).

#### Enclosure Dimensions:

ALTV2416300ULM and ALTV2416300ULCBM:  
8.5"H x 7.5"W x 3.5"D  
ALTV2416ULX, ALTV2416ULCBX, ALTV2416300UL,  
ALTV2416300ULCB, ALTV2416600UL and  
ALTV2416600ULCB:  
13"H x 13.5"W x 3.25"D

## **Installation Instructions:**

1. Mount unit in desired location.
2. Set power switch on power distribution board marked [PD] to OFF position for models ALTV2416ULX or ALTV2416ULCBX (Figs. 1, 2, pgs. 4, 5). Set power disconnect circuit breaker to OFF position for all other models (Figs. 3A-8A, pgs. 6-10).
3. All units are factory set for 24VAC operation.  
For 28VAC operation, adjust unit prior to mounting and applying power as follows:  
Change the wire position so that the wire marked [28V] is connected to the terminal marked [P] and the wire marked [24V] is connected to the terminal marked [S].  
**Note: ALTV2416ULCBX set for 28VAC operation is not Class 2 Rated, not power limited.**
4. Connect AC power to the black and white flying leads of the transformer(s) (Figs. 1-8, pgs. 4-10), secure green lead to earth ground. Use 18 AWG or larger for all power connections.  
**Keep power limited (PTC protected outputs only) wiring separate from non-power limited wiring. Minimum .25" spacing must be provided. Use separate knockouts.**
5. Set power switch on power distribution board marked [PD] to ON position for models ALTV2416ULX or ALTV2416ULCBX (Figs. 1, 2, pgs. 4, 5). Set power disconnect circuit breaker to RESET (ON) position for all other models (Figs. 3A-8A, pgs. 6-10).
6. Measure output voltage before connecting devices. This helps avoid potential damage.  
Terminals marked [1P - 16P] are of the same polarity.  
**CAUTION: Determine the maximum operating voltage of the equipment being powered before adjusting the output voltage.**
7. Set power switch on power distribution board marked [PD] to OFF position for models ALTV2416ULX or ALTV2416ULCBX (Figs. 1, 2, pgs. 4, 5). Set power disconnect circuit breaker to OFF position for all other models (Figs. 3A-8A, pgs. 6-10).
8. Connect devices to terminals marked [1P - 1N through 8P - 8N] on PD8 board (Figs. 1-4, 7, 8, pgs. 4-7, 9, 10), or terminals marked [1P - 1N through 16P - 16N] on PD16W/PD16WCB board (Fig. 5, pg. 8), carefully observing polarity.
9. Set power switch on power distribution board marked [PD] to ON position for models ALTV2416ULX or ALTV2416ULCBX (Figs. 1, 2, pgs. 4, 5). Set power disconnect circuit breaker to RESET (ON) position for all other models (Figs. 3A-8A, pgs. 6-10).
10. Green LED will illuminate when power is present.
11. Upon completion of wiring, secure enclosure door with screws (supplied). Installation of cam lock is optional.  
**Caution: Equipment to be installed/serviced by authorized/trained personnel only.**  
**Shut branch circuit power before installing/servicing equipment.**

**WARNING: To reduce the risk of fire or electric shock, do not expose the unit to rain or moisture. This installation should be made by qualified service personnel and should conform to all local codes and in accordance with the National Electrical Code. Use 75° C or higher rated UL insulated wiring for connecting the unit to the mains. Replace fuses only with the same type and rating (refer to Sixteen (16) Output ALTV2416UL Reference Chart, pg. 2)**

### **Terminal Identification:**

#### **PD8 - Power Distribution Module**

1P - 8P	AC output.
1N - 8N	AC output.

#### **PD16W - Power Distribution Module**

1P - 16P	AC output.
1N - 16N	AC output.



The lightning flash with arrow head symbol within an equilateral triangle is intended to alert the user to the presence of an insulated “DANGEROUS VOLTAGE” within the products enclosure that may be of sufficient magnitude to constitute an electric shock.



The exclamation point within an equilateral triangle is intended to alert the user to the presence of important operating and maintenance (servicing) instructions in the literature accompanying the appliance.



**CAUTION**  
RISK OF ELECTRIC SHOCK  
DO NOT OPEN



**CAUTION:** To reduce the risk of electric shock do not open enclosure. There are no user serviceable parts inside. Refer servicing to qualified service personnel.

Fig. 1  
ALTV2416ULX

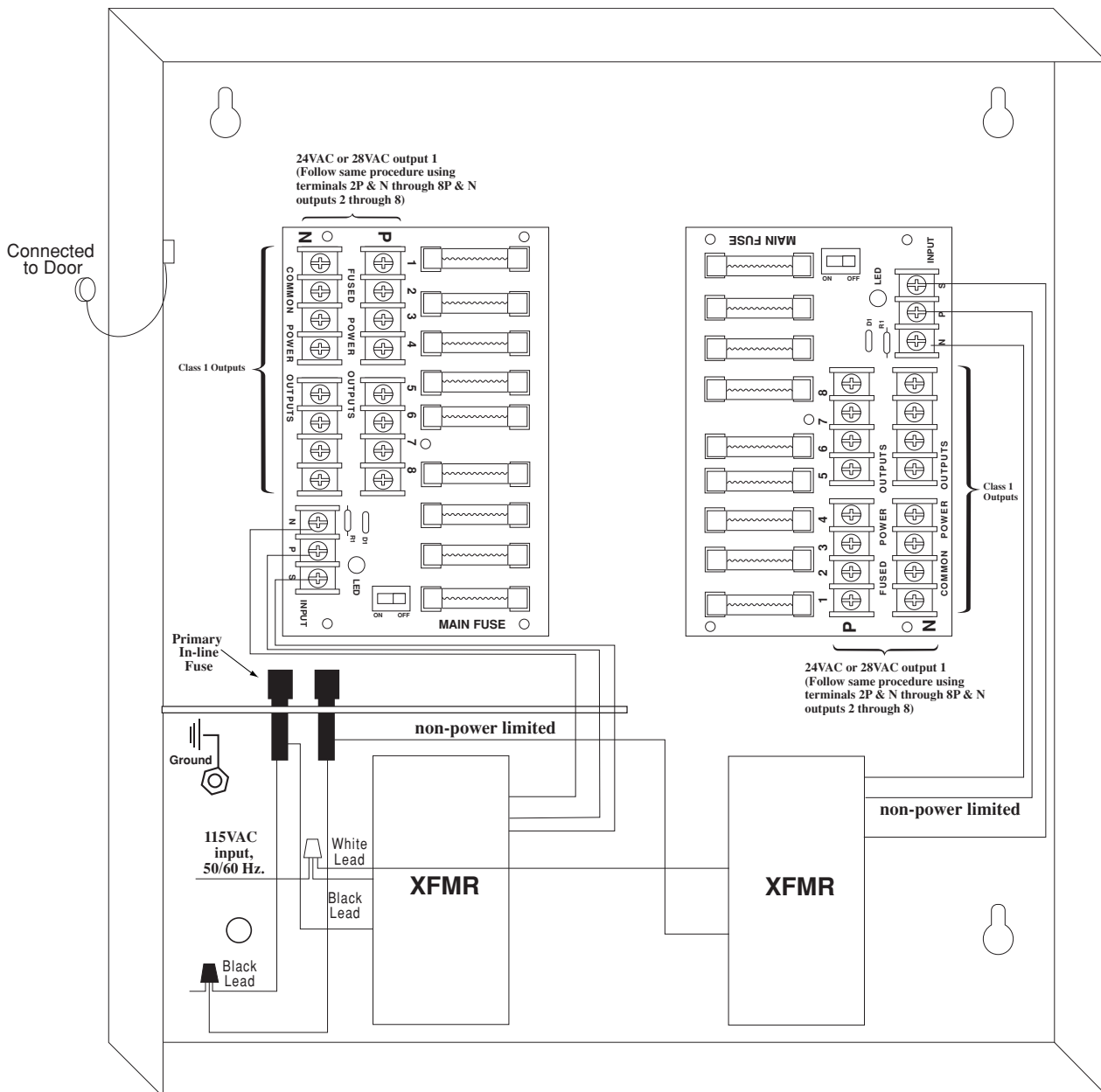

Fig. 2  
ALTV2416ULCBX

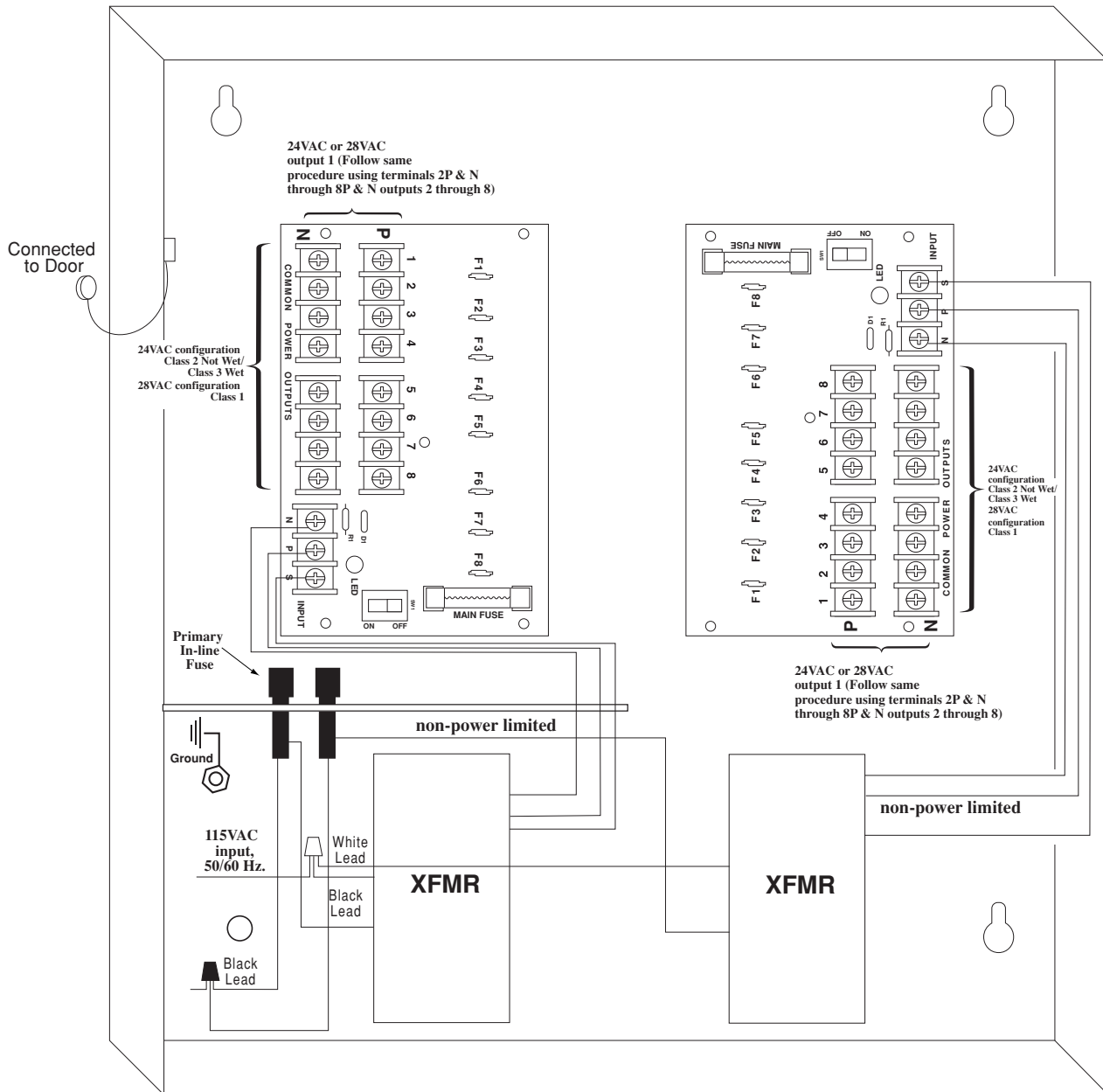

Fig. 3  
ALTV2416300UL

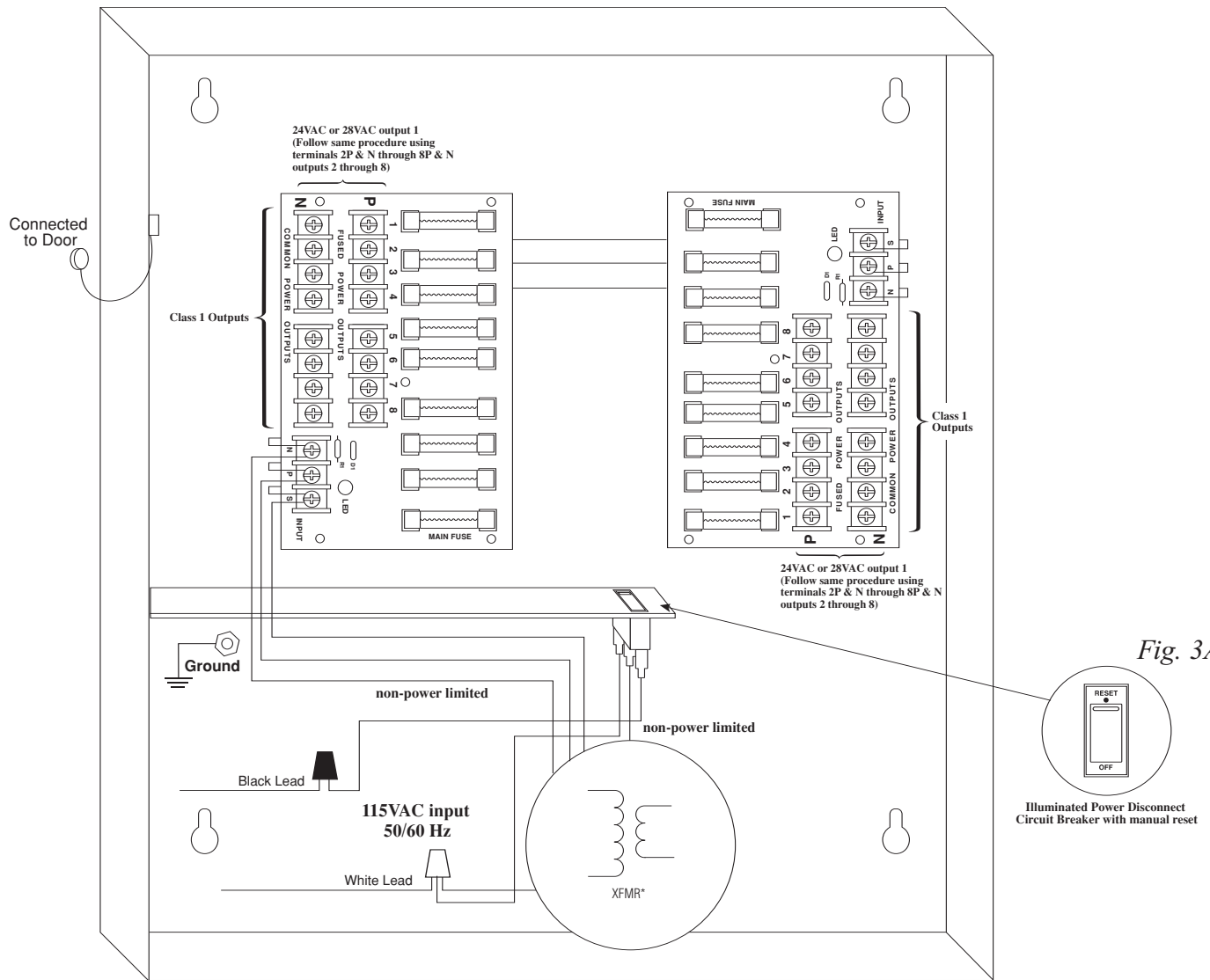

Fig. 4  
ALTV2416300ULCB

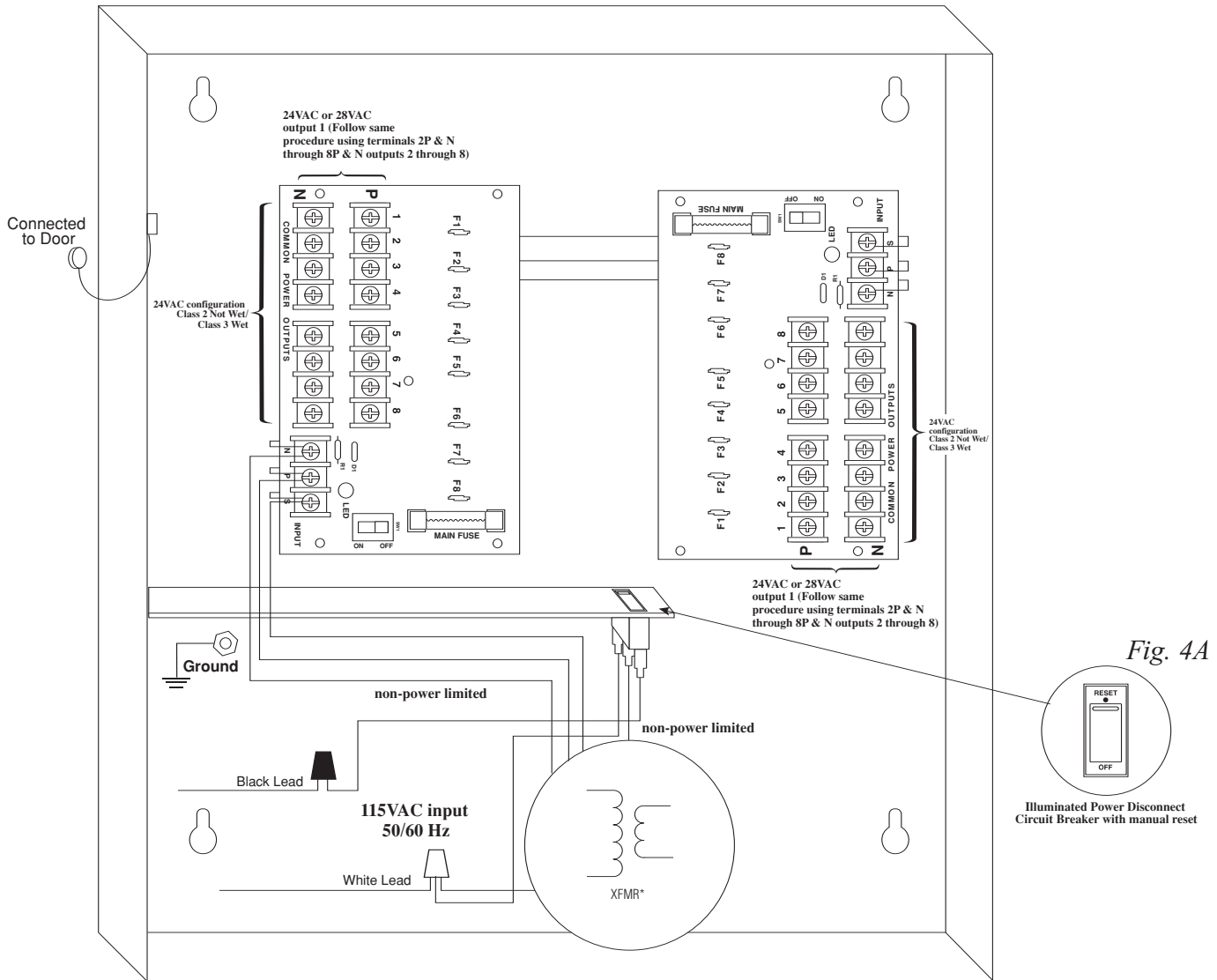

Fig. 4A

Fig. 5  
ALTV2416300ULM

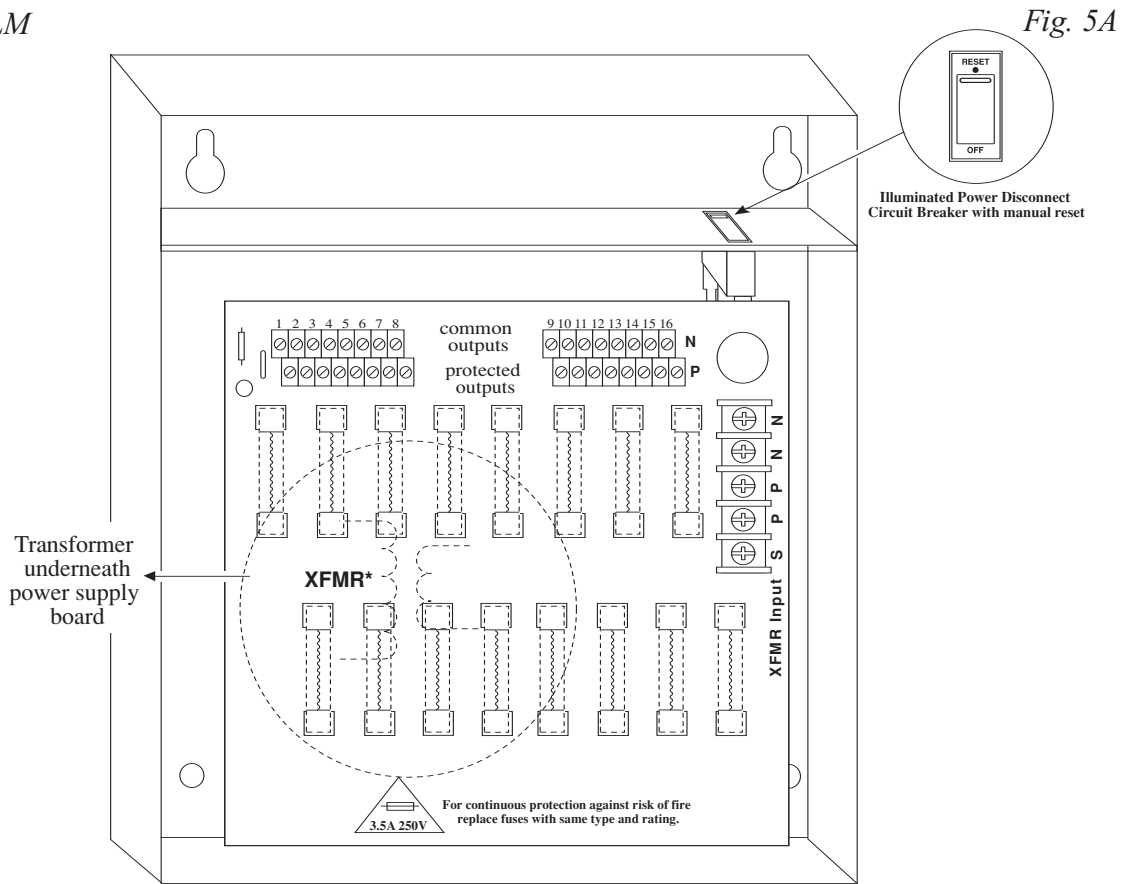

Fig. 6  
ALTV2416300ULCBM

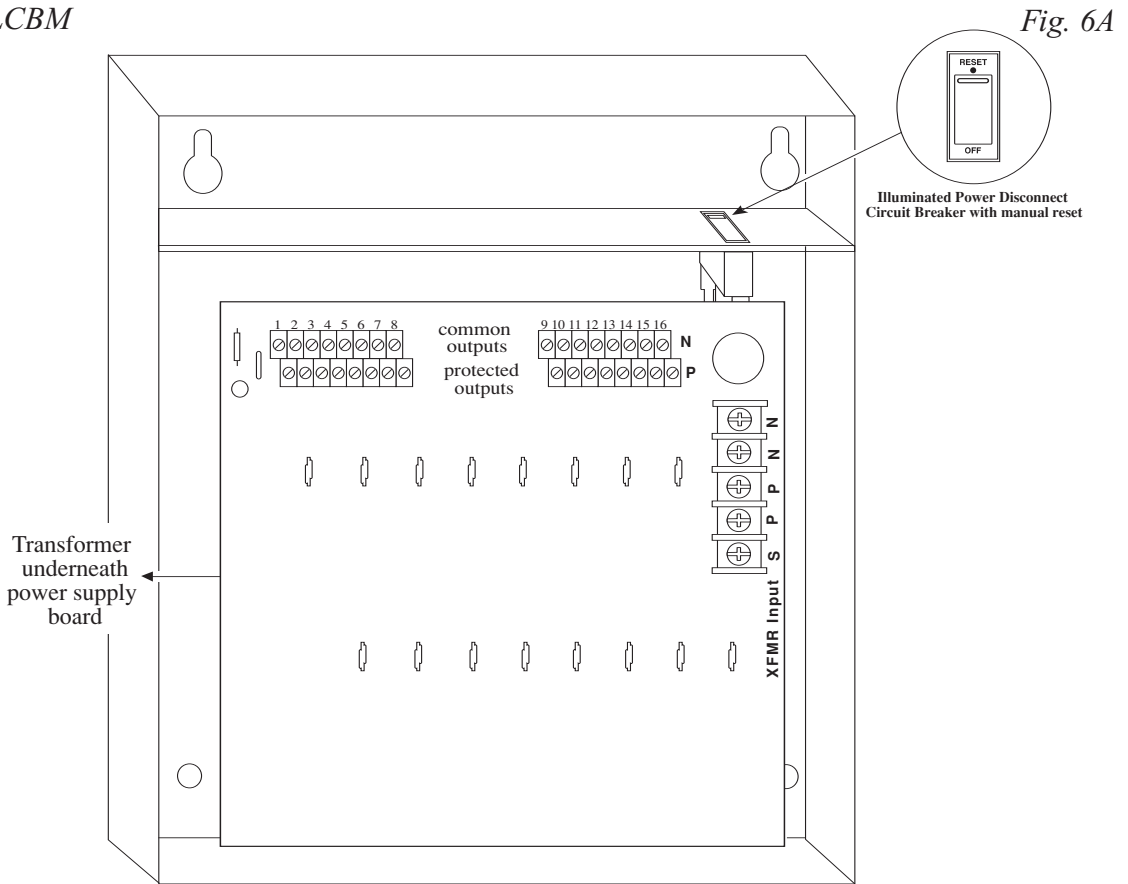

Fig. 7  
ALTV2416600UL

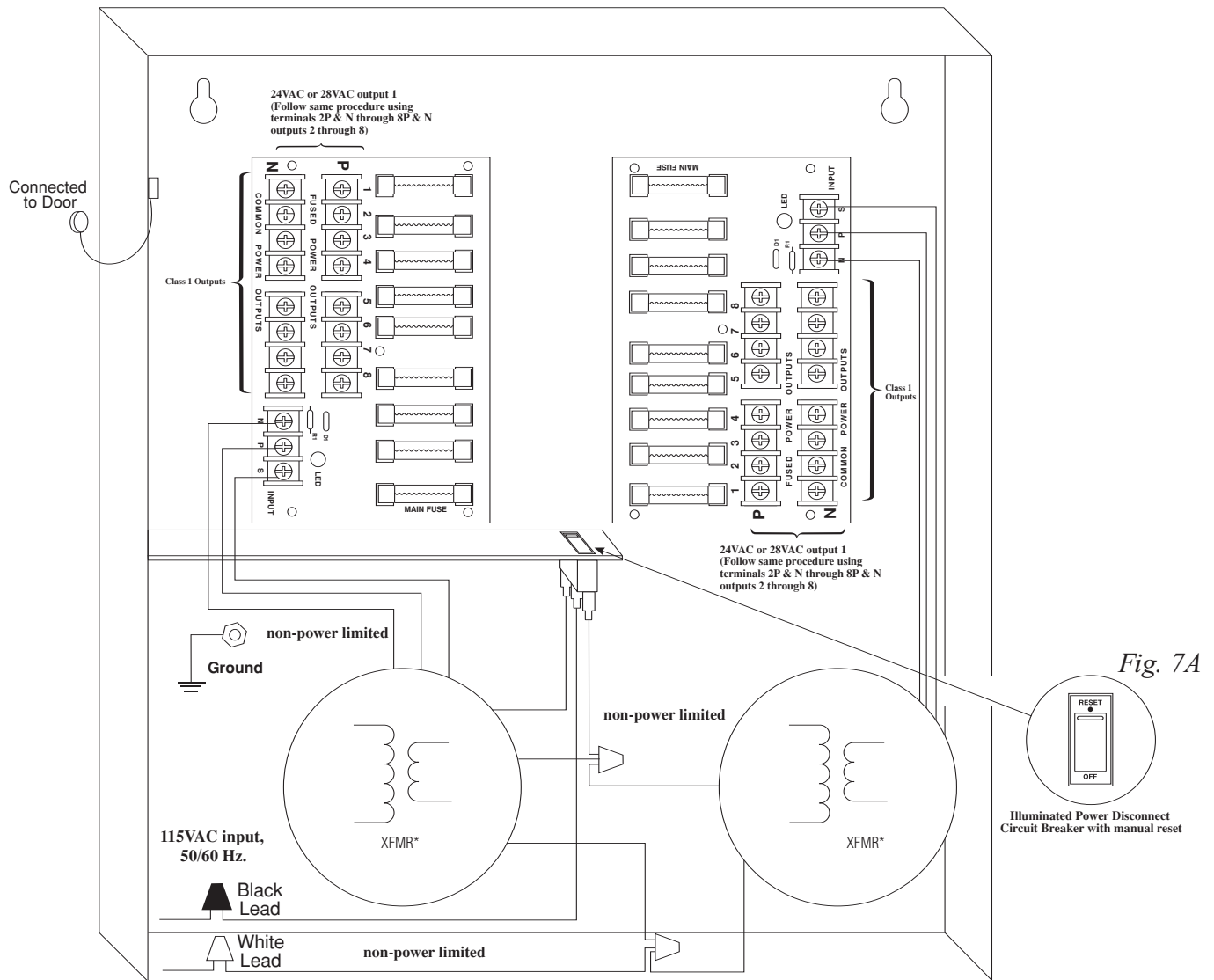
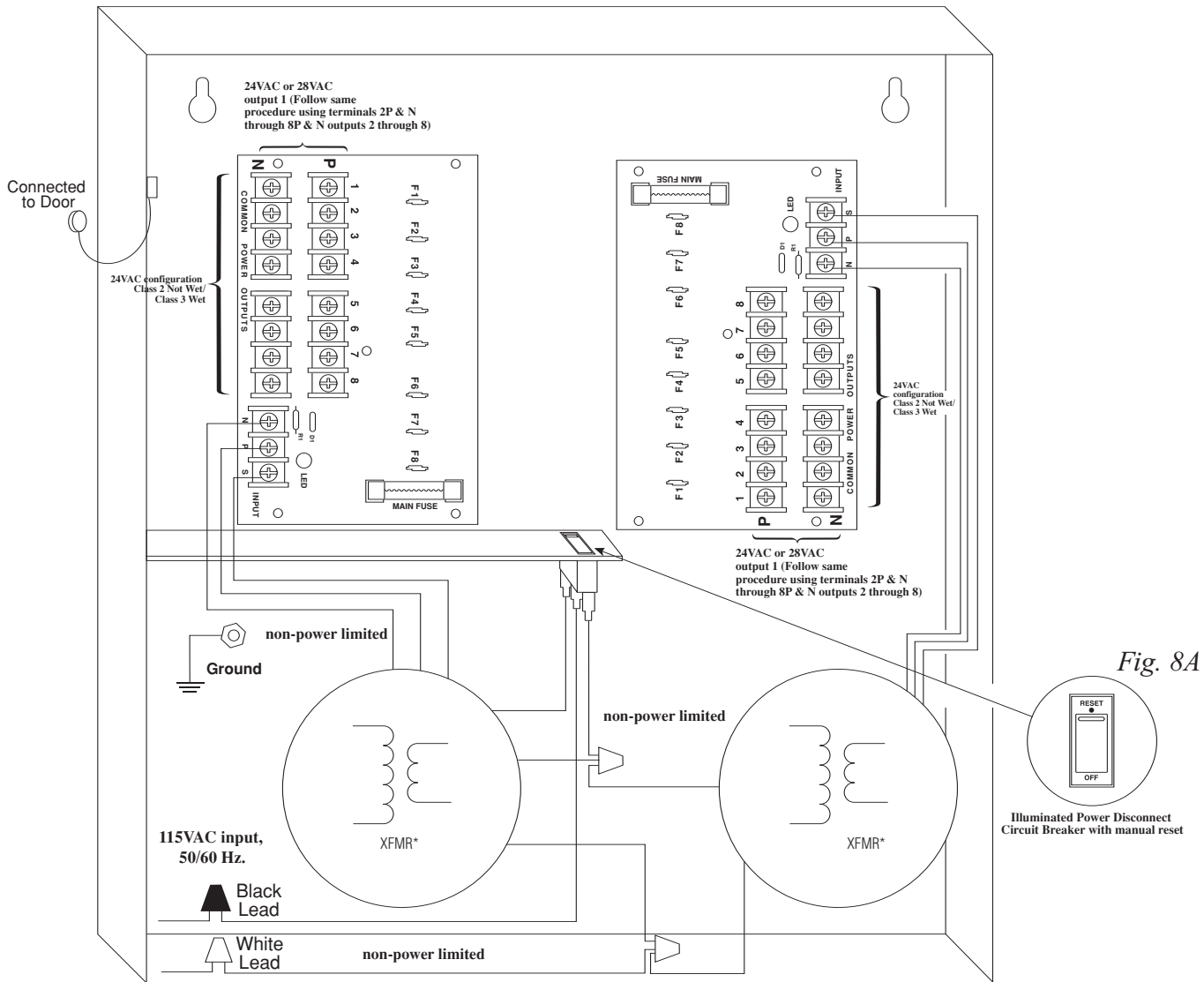

Fig. 8  
ALTV2416600ULCB



**Enclosure Dimensions for:**

• **ALTV2416300ULM**

• **ALTV2416300ULCBM**

8.5"H x 7.5"W x 3.5"D

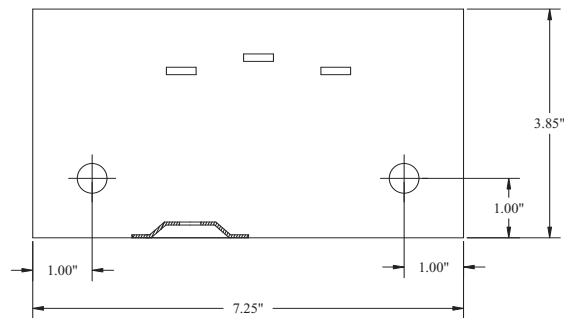
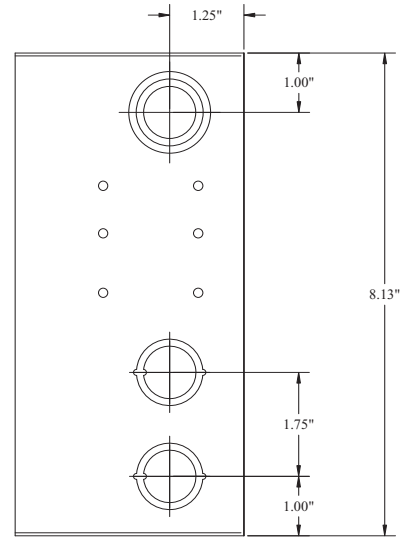
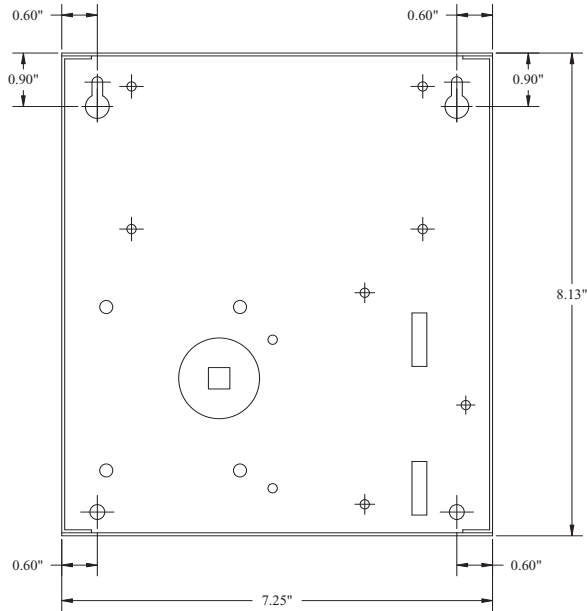
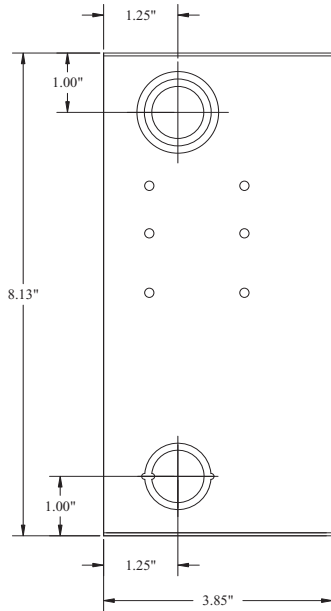
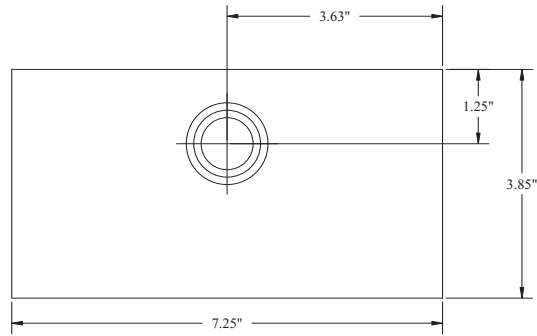

**Enclosure Dimensions for:**

- **ALTV2416ULX**
- **ALTV2416ULCBX**
- **ALTV2416300UL**
- **ALTV2416300ULCB**
- **ALTV2416600UL**
- **ALTV2416600ULCB**

13"H x 13.5"W x 3.5"D

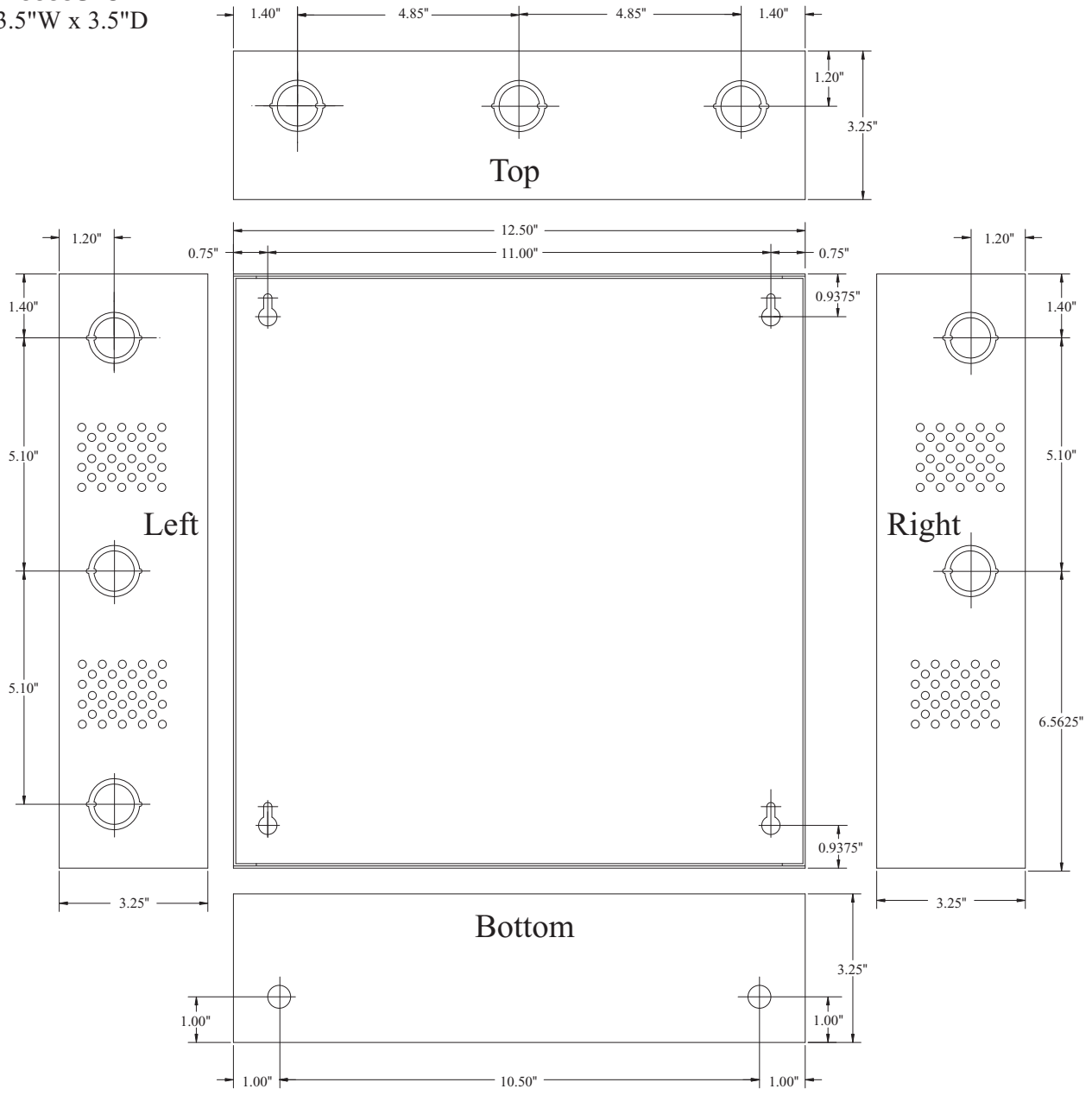

Altronix is not responsible for any typographical errors.

Altronix Corp.  
 140 58th Street, Brooklyn, New York 11220 USA, 718-567-8181, fax: 718-567-9056  
 web site: [www.altronix.com](http://www.altronix.com), e-mail: [info@altronix.com](mailto:info@altronix.com), Lifetime Warranty, Made in U.S.A.  
 III1ALTV2416ULSeries D05F

