

Overview:

ALTV1224DC DC CCTV power supply is designed to power CCTV Cameras and accessories. It will provide 12VDC or 24VDC distributed via eight (8) fused outputs with a total of 4 amp total continuous supply current.

Specifications:

Input:

- Input 115VAC 50/60Hz, 1.45 amp.

Output:

- Eight (8) individual fused outputs.
- 4 amp total continuous supply current.
- 12VDC or 24VDC selectable output.

Fuse Ratings:

- Input fuse rated at 3.5 amp / 250V.
- Output fuses are rated at 1 amp / 250V (Fig. 1).

Visual Indicators:

- AC input and DC output LED indicator.

Additional Features:

- Filtered and electronically regulated outputs.
- Power ON/OFF switch.
- Spare fuses included.
- Unit maintains camera synchronization.
- Ease of installation saves time and eliminates costly labor.

Enclosure Dimensions:

13.5"H x 13"W x 3.25"D

Optional 220VAC input available order model # ALTV1224DC/220.

Power Supply Output Specifications:

Output VDC	Switch Position	Maximum Load DC
12VDC	SW1 Closed	4 amp
24VDC	SW1 Open	4 amp

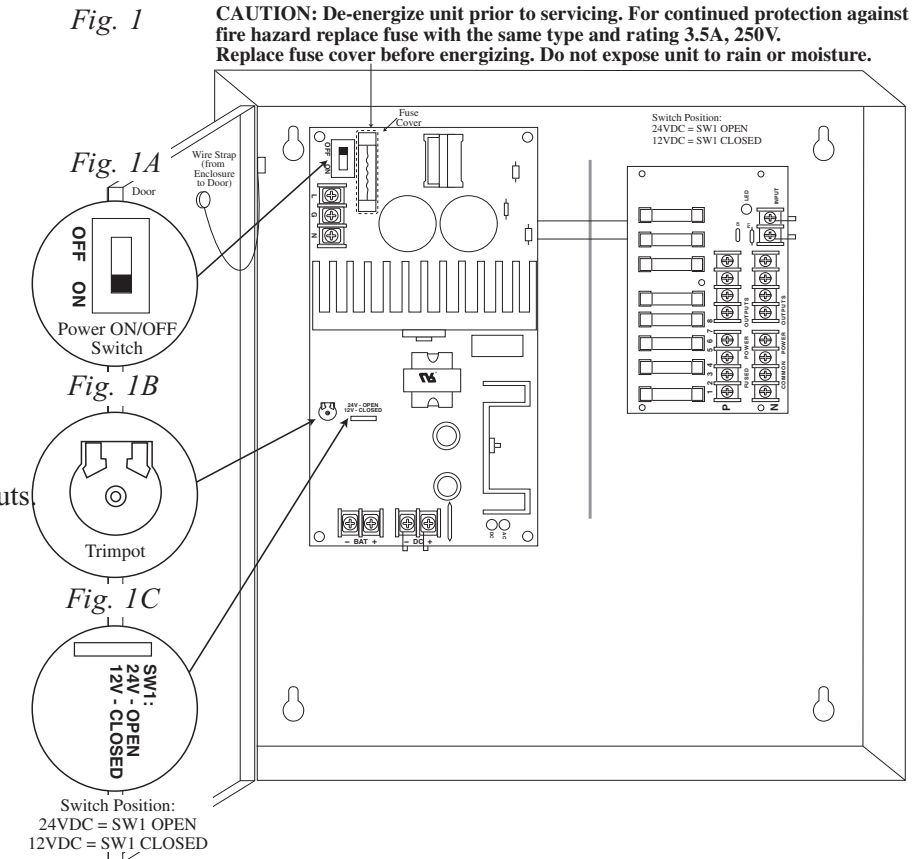

Installation Instructions:

1. Mount ALTV1224DC enclosure in desired locations.
2. Slide switch to OFF position (Fig. 1A).
3. Set the ALTV1224DC to desired DC output voltage range by setting switch (SW1) on the power supply board to the appropriate position (Power Supply Output Specification Table) (Fig. 1C).
Use trimpot to adjust voltage if necessary (Fig. 1B).
4. Connect the AC (115VAC 50/60 Hz) to the terminals marked L and N. Connect earth ground to G terminal (Fig. 1).
5. **Measure output voltage before connecting devices.** This helps avoid potential damage.
6. Connect each DC device to output terminals 1 through 8. (Fig. 1).
Note: Be careful to observe camera polarity.
7. When batteries are being used the DC output voltage must be adjusted by turning the trim pot VR1 (Fig. 1B) clockwise to increase the output voltage to 13.7VDC for 12VDC operation and 27.1VDC for 24VDC operation.
Connect battery to terminals marked [- BAT+] (battery leads included) (Fig. 1).
Use two (2) 12VDC batteries connected in series for 24VDC operation.
8. Slide switch to ON position (Fig. 1A).
9. Green LED on the PD8 board will illuminate when power is present.
10. Upon completion of wiring, secure enclosure door with screws (supplied).

WARNING: To reduce the risk of fire or electric shock, do not expose the unit to rain or moisture. This installation should be made by qualified service personnel and should conform to all local codes and in accordance with the National Electrical Code.

**Terminal Identification:
OLS127 - Power Supply**

Terminal Legend	Function/Description
L, G, N	115VAC 50/60 Hz connections
+ DC -	12VDC or 24VDC @ 4 amp total continuous output.
- BAT +	Stand-by battery connections. Maximum charge rate .5 amp.

PD8 - Distribution Module

1P - 8P	Positive DC power outputs.
1N - 8N	Negative DC power outputs.

**Enclosure Dimensions:
13.5"H x 13"W x 3.25"D**

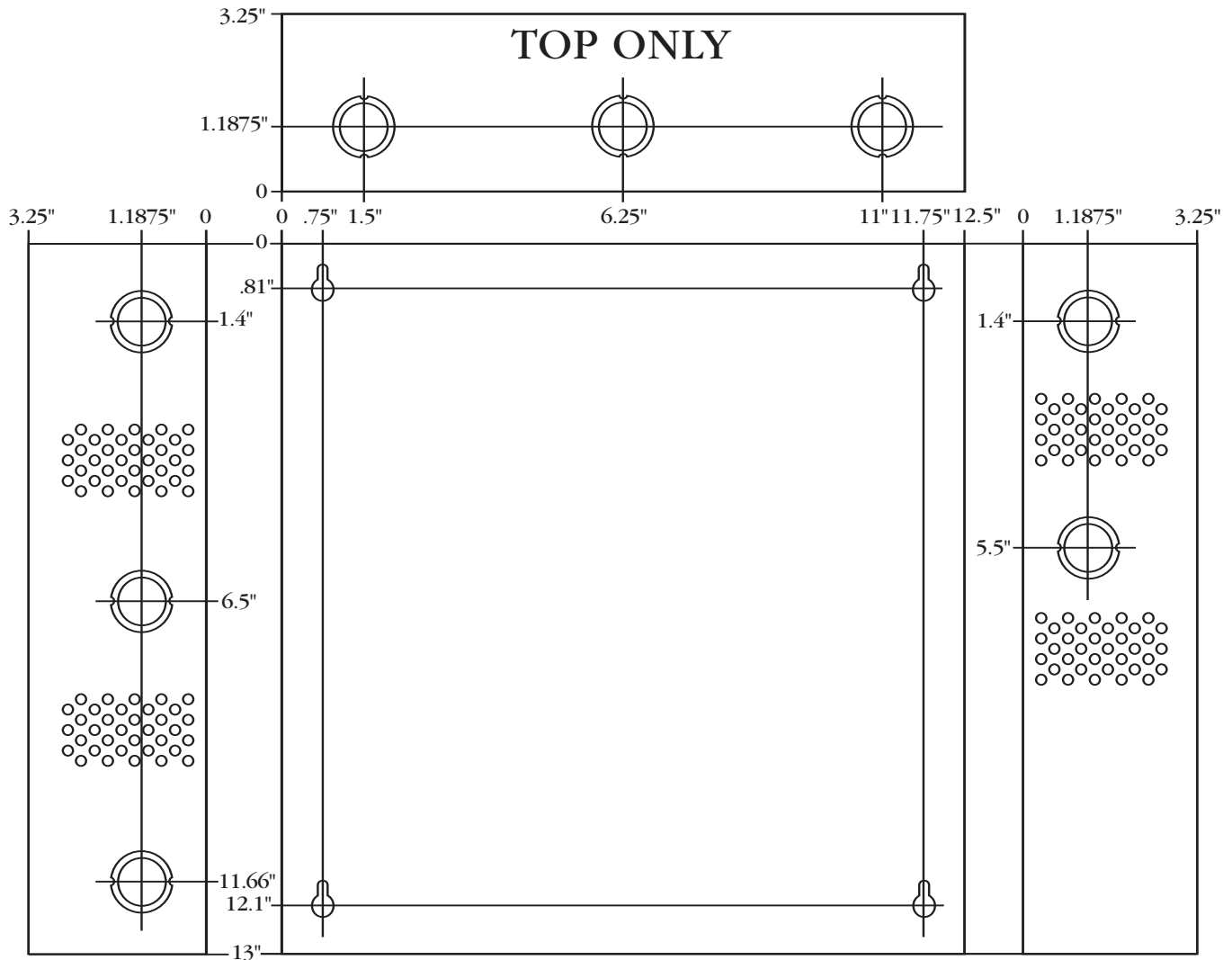

Altronix is not responsible for any typographical errors. Product specifications are subject to change without notice.

