



# AL300ULXD - Power Supply/Charger

Rev. 062101

### Overview:

The AL300ULXD is a power supply/charger that will convert a 115 VAC or 230VAC / 50/60Hz input, into a power limited 12VDC or 24VDC output, (see specifications).

### Specifications:

- UL Listed - For Fire, Burglar and Access Control Power Supply Systems. (UL1481, UL603, UL294)
- CE Approved.
- Switch selectable 12VDC or 24VDC power limited output.
- Class 2 rated.
- Input 115VAC 50/60Hz, .9 amp or 230VAC 50/60Hz .45 amp.
- Maximum charge current 600mA.
- 2.5 amp continuous supply current at 12VDC or 24VDC.
- Filtered and electronically regulated outputs.
- Built-in charger for sealed lead acid or gel type batteries.
- Automatic switch over to stand-by battery when AC fails.
- AC input and DC output LED indicators.
- AC fail supervision (form "C" contacts).
- Low battery supervision (form "C" contacts).
- Low battery disconnect prevents batteries from deep discharge.
- Thermal overload protection.
- Short circuit protection.
- Unit is complete with power supply, grey enclosure, cam lock and transformer.
- Includes battery leads.



Enclosure Dimensions: 15.5”H x 12”W x 4.5”D

**Note:** Enclosure accommodates up to two (2) 12AH batteries

### Power Supply Output Specifications:

Output VDC	Switch Position
12VDC	SW1, 2 ON, SW3, 4 OFF
24VDC	SW1, 2 OFF, SW3, 4 ON

### Stand-by Specifications:

Output	4 hr. of Stand-by & 5 Minutes of Alarm	24 hr. of Stand-by & 5 Minutes of Alarm	60 hr. of Stand-by & 5 Minutes of Alarm
12VDC / 40 AH Battery	Stand-by = 2.5 amp Alarm = 2.5 amp	Stand-by = 1.0 amp Alarm = 2.5 amp	Stand-by = 300mA Alarm = 2.5 amp
24VDC / 12 AH Battery		Stand-by = 200mA Alarm = 2.5 amp	
24VDC / 40 AH Battery	Stand-by = 2.5 amp Alarm = 2.5 amp	Stand-by = 1.0 amp Alarm = 2.5 amp	Stand-by = 300mA Alarm = 2.5 amp

### Installation Instructions:

The AL300ULXD should be installed in accordance with article 760 of The National Electrical Code or NFPA 72 as well as all applicable Local Codes.

1. Mount the AL300ULXD in desired location.
2. Connect input power to the transformer. Secure green wire lead to earth ground. (Fig. 1).  
 For 115VAC input: Connect Yellow and White leads from transformer primary to neutral.  
 Connect Blue and Black leads from transformer primary to line (Fig. 2).  
 For 230VAC input: Connect Blue and Yellow leads of transformer together.  
 Connect White lead from transformer to neutral.

Connect Black lead from transformer to line (Fig. 2).

Use 18 AWG or larger for all power connections (Battery, DC output).

Use 22 AWG to 18 AWG for power limited circuits (AC Fail/Low Battery reporting).

**Keep power limited wiring separate from non-power limited wiring (115VAC 50/60Hz or 230 50/60Hz Input, Battery Wires). Minimum .25" spacing must be provided.**

3. Connect devices to be powered to terminals marked [- DC +] (Fig. 1).  
**Note:** It is important to measure output voltage before connecting devices. This helps avoid potential damage.
4. For Access Control applications, batteries are optional. When batteries are not used a loss of AC will result in the loss of output voltage. When the use of stand-by batteries is desired, they must be lead acid or gel type. Connect battery to terminals marked [- BAT +] (Fig. 1). Use two (2) 12VDC batteries connected in series for 24VDC operation (battery leads included).
5. Connect appropriate signaling notification devices to AC Fail & Low battery (Fig. 1) supervisory relay outputs.

**Maintenance:**

Unit should be tested at least once a year for the proper operation as follows:

**Output Voltage Test:** Under normal load conditions, the DC output voltage should be checked for proper voltage level (see power supply voltage output specifications chart).

**Battery Test:** Under normal load conditions check that the battery is fully charged, check specified voltage both at battery terminal and at the board terminals marked [- BAT +] to insure there is no break in the battery connection wires.

**Note:** Maximum charging current under discharges is 600mA.

**Note:** Expected battery life is 5 years, however it is recommended changing batteries in 4 years or less if needed.

**Fig. 2 - 115VAC Input**

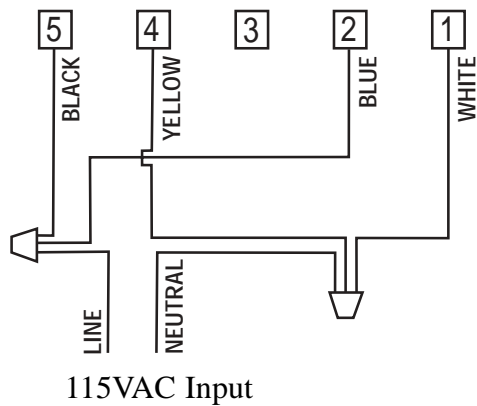

**Fig. 3 - 230VAC Input**

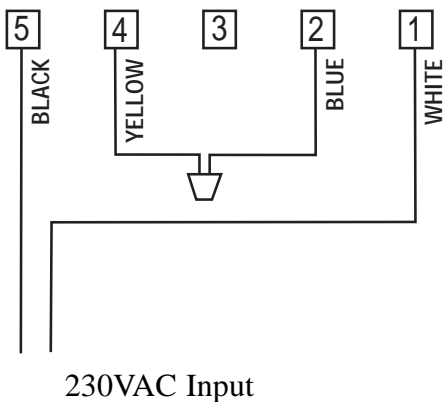

**Fig. 1**

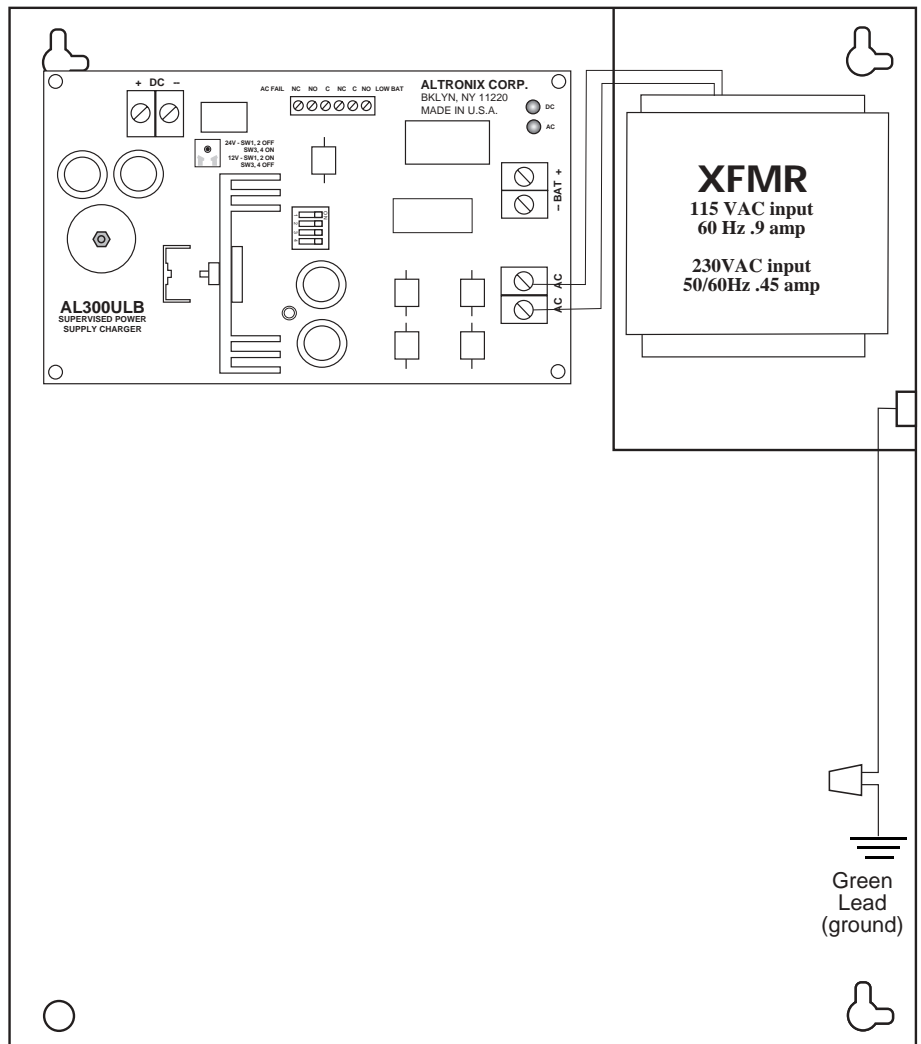

### LED Diagnostics:

Red (DC)	Green (AC)	Power Supply Status
ON	ON	Normal operating condition
ON	OFF	Loss of AC, Stand-by battery supplying power
OFF	ON	No DC output
OFF	OFF	Loss of AC. Discharged or no stand-by battery. No DC output.

### Terminal Identification:

Terminal Legend	Function/Description
AC / AC	Low voltage AC input (28VAC / 100VA).
-DC +	12VDC / 24VDC @ 2.5 amp continuous power limited output.
AC FAIL N.C., C, N.O.	Used to notify loss of AC power, e.g. connect to audible device or alarm panel. Relay normally energized when AC power is present. Contact rating 1 amp @ 120VAC / 28VDC
LOW BAT N.O., C, N.C.	Used to indicate low battery condition, e.g. connect to alarm panel. Relay normally energized when DC power is present. Contact rating 1 amp @ 120VAC / 28VDC
- BAT +	Stand-by battery connections. Maximum charge rate 600mA.

**Enclosure Dimensions:**

15.5"H x 12"W x 4.5"D

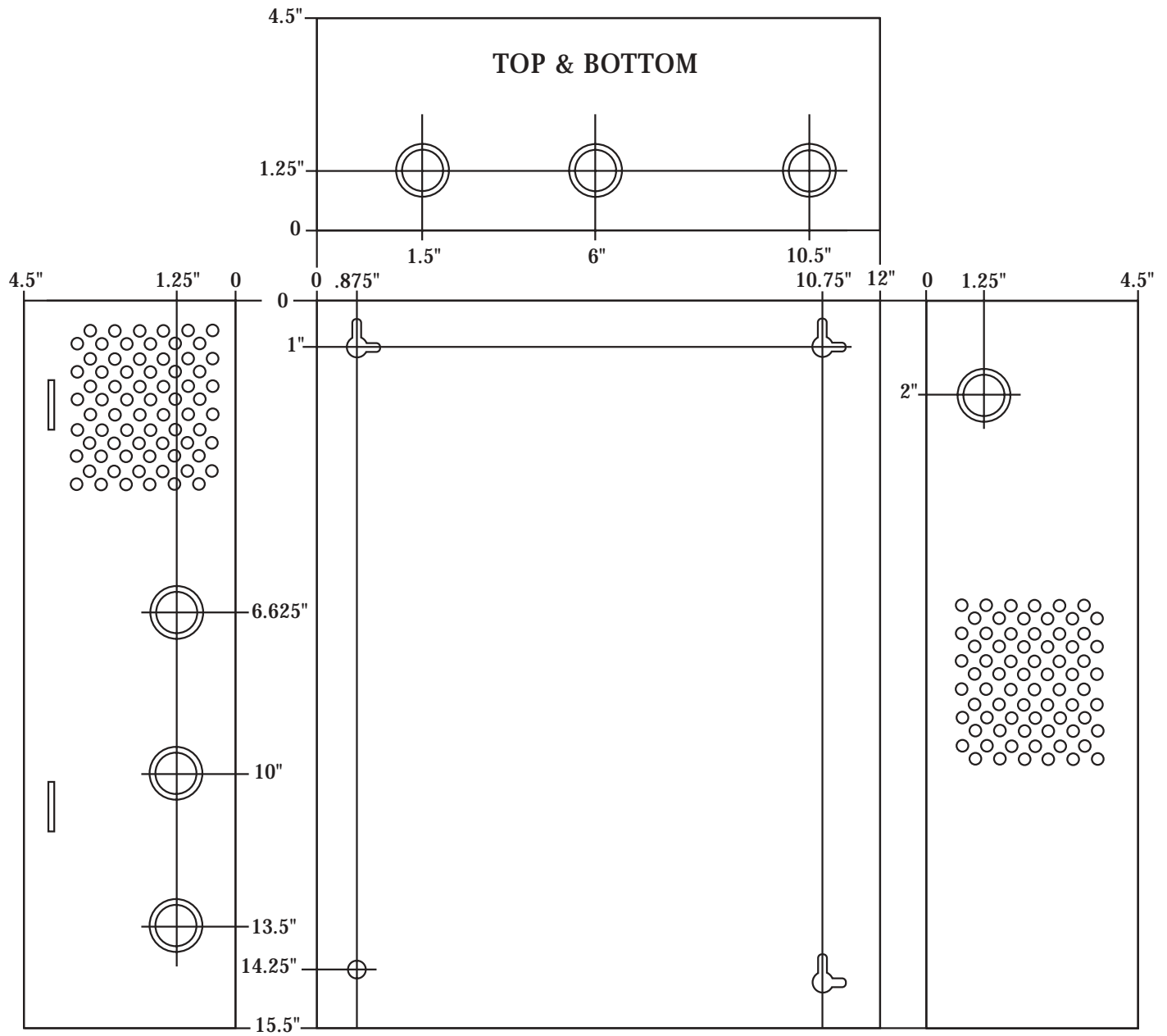

Altronix is not responsible for any typographical errors. Product specifications are subject to change without notice.