



AL175ULB Access Control Power Supply/Charger

Rev. 081601

Overview:

AL175ULB is a power limited power supply/chargers that will convert a 28VAC input, into two (2) individual PTC protected 12VDC or 24VDC output, (see specifications). They are intended for use in applications requiring UL Listing for Access Control (UL294) and applications requiring an interface with Fire Alarm Control Panels.

Specifications:

Agency Listings:

- UL Recognized component for Access Control Systems (UL294).

Input:

- 28VAC, 56VA.
- Fire Alarm Panel or Access Control System trigger inputs.

Output:

- Class 2 Rated power limited outputs.
- 12VDC or 24VDC selectable power limited outputs.
- 1.75 amp continuous supply current @ 12VDC or 24VDC.
- One (1) triggerable and one (1) constant output.
- Filtered and electronically regulated output.
- Aux relay output (form "C" 1 amp @ 28VDC).

Battery Backup:

- Built-in charger for sealed lead acid or gel type batteries.
- Maximum charge current: 400mA.
- Automatic switch over to stand-by battery when AC fails.

Visual Indicators:

- AC input and DC output LED indicators.

Additional Features:

- Short circuit and thermal overload protection.
- Includes power supply and battery leads.
- AC Fail output relay (form "C" 1 amp @ 28VDC).

Board Dimensions (approximate):

3.1"W x 5.8"L x 1.5"H

Power Supply Output Specifications:

Output VDC	Switch Position	Max. Stand-by Load DC	Max. Alarm Load DC	Battery (optional)
12VDC	SW1 Open	1.75 amp	1.75 amp	12VDC
24VDC	SW1 Closed	1.75 amp	1.75 amp	24VDC

Stand-by Specifications:

Output	4 hr. of Stand-by & 5 Minutes of Alarm
12VDC / 7 AH Battery	Stand-by = 1.25 amp
24VDC / 7 AH Battery	Alarm = 1.25 amp

Installation Instructions:

The AL175ULB should be installed in accordance with article 760 of The National Electrical Code or NFPA 72 as well as all applicable Local Codes.

See Terminal Identification Chart on page 3 for a description of each terminal function.

1. Mount the AL175ULB in desired location/enclosure.
2. Connect 28VAC, 56VA transformer to terminals marked [AC, AC]..

Use 18 AWG or larger for all power connections (Battery, DC output). Use 22 AWG to 18 AWG for power limited circuits (trigger inputs, dry outputs).

Keep power limited wiring separate from non-power limited wiring (115VAC / 60Hz Input, Battery Wires). Minimum .25" spacing must be provided.



3. Set the AL175ULB to the desired DC output voltage by setting switch SW1 to the appropriate position (power supply output specification table).
4. Measure output voltage before connecting devices. This helps avoid potential damage.
5. Connect battery to terminals marked [+ BAT -] on the unit (battery leads included). Use two (2) 12VDC batteries connected in series for 24VDC operation.
Note: For Access Control applications, batteries are optional. When batteries are not used a loss of AC will result in the loss of output voltage. When the use of stand-by batteries are desired, they must be lead acid or gel type.
6. Connect appropriate signaling notification devices to AC Fail supervisory relay outputs.
Note: To meet UL requirements, AC Supervisory outputs must be connected to the zone of Alarm Control Panel or to visual AC trouble indicator.
7. For Access Control Device & Fire Alarm Interface connections refer to desired Typical Application Diagrams (pg. 4) and Terminal Identification Chart (pg. 2).

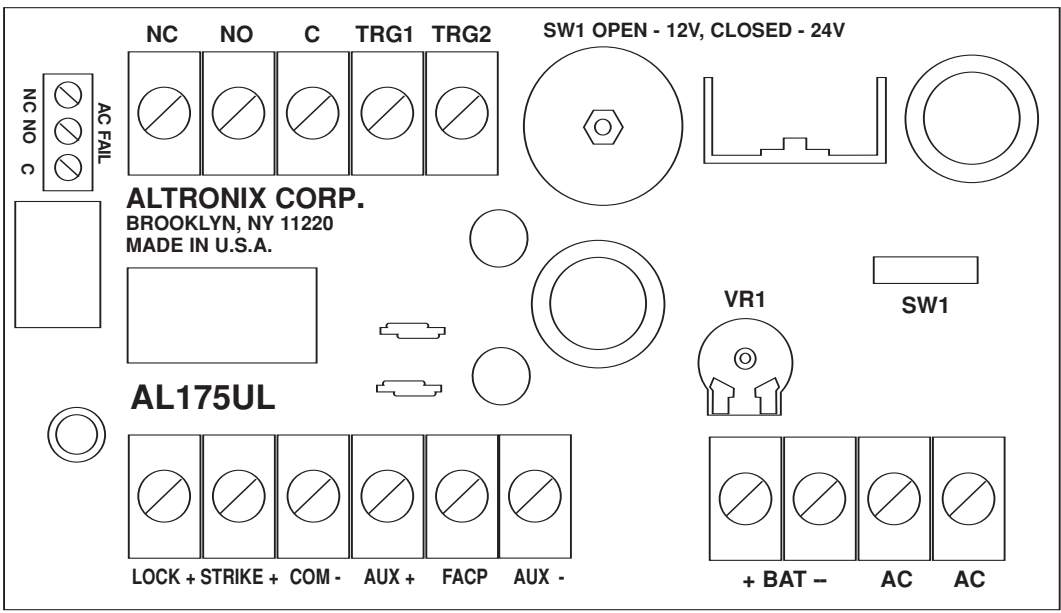

Maintenance:

Unit should be tested at least once a year for the proper operation as follows:
 Output Voltage Test: Under normal load conditions, the DC output voltage should be checked for proper voltage level (*Power Supply Output Specifications Chart*).
 Battery Test: Under normal load conditions check that the battery is fully charged, check specified voltage both at battery terminal and at the board terminals marked [- BAT +] to insure there is no break in the battery connection wires.
Note: Maximum charging current under discharge is 400mA.
Note: Expected battery life is 5 years, however it is recommended changing batteries in 4 years or less if needed.

LED Diagnostics:

Red (DC)	Green (AC)	Power Supply Status
ON	ON	Normal function.
ON	OFF	Battery backup is powering output.
OFF	ON	No DC output.
OFF	OFF	Loss of AC. Discharged or missing stand-by battery. No DC output.

Terminal Identification:

Terminal Legend	Function/Description
AC	Low voltage AC input.
TRG1 & TRG2	These input terminals are designed to connect to the normally closed outputs of an access control or fire alarm relay. These terminals control [LOCK+], and [STRIKE+], as well as AL175ULB output relay contacts [N.C., N.O., C]
LOCK+	This terminal provides DC output voltage when [TRG1] and [TRG2] are shorted together and are typically used to power Mag Locks.
STRIKE+	This terminal provides DC output voltage when [TRG1] and [TRG2] are unshorted and are typically used to power Electric Strikes.
N.C., N.O., C	Isolated dry Form “C” contacts. Shorting [TRG1] and [TRG2] together causes these contacts to switch. They are typically used for controlling multiple AL175ULBs with fire alarm tie-in (<i>Fig. 4 and Fig. 5, pg. 4</i>).
AUX +	Continuous positive (+) DC power output voltage. It is not affected by TRG1, TRG2 operation.
COM -	Common negative (-) output (ground).
FACP	Spare wiring terminal used for fire alarm tie-in application (<i>Fig. 3, pg. 4</i>).
+ BAT -	Stand-by battery connections.
AC FAIL N.C., C, N.O.	Used to notify loss of AC e.g connect audible device or alarm panel relay normally energized When AC power is present. Contact rating 1 amp @ 28VDC.

Typical Application Diagrams:

Fig. 1 - Typical single mag lock or door strike installation with fire alarm tie-in using trigger controlled output:

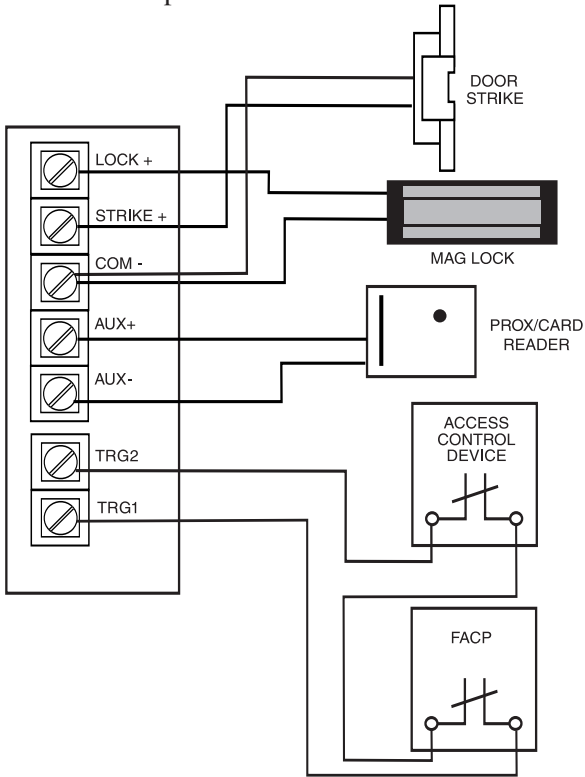

Fig. 3 - Typical mag lock with fire alarm tie-in using aux output installation:

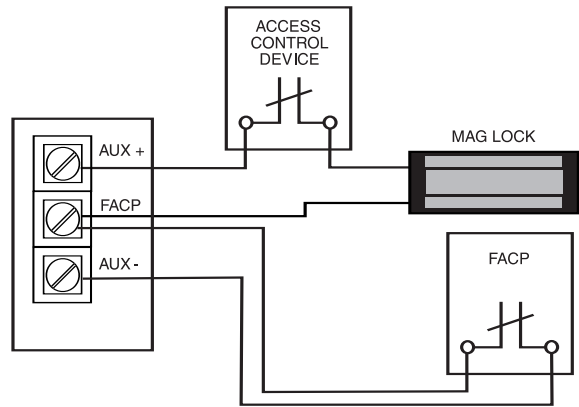

Fig. 4 - Latching fire alarm tie-in with manual reset:

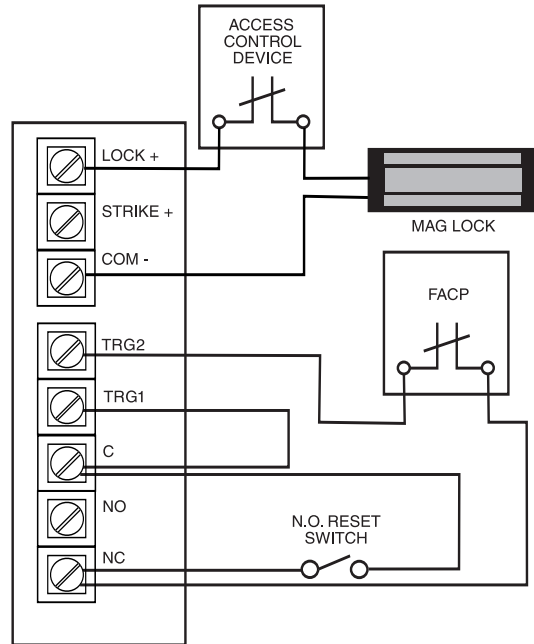

Fig. 2 - Typical dual mag lock installation with fire alarm tie-in using trigger controlled outputs:

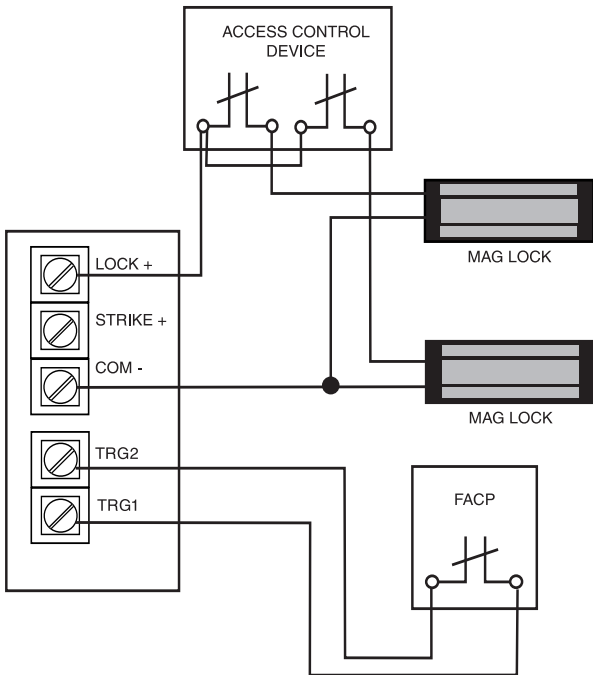
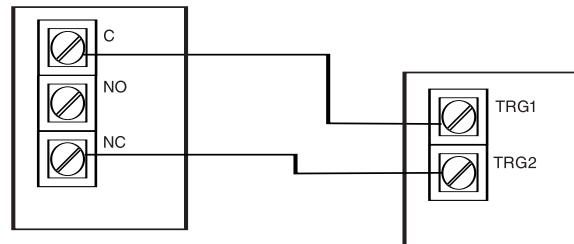

Fig. 5 - Multiple AL175UL(X) power supply connections:



Altronix is not responsible for any typographical errors.